



Count on it.

Operator's Manual

122cm TITAN[®] HD 1500 Series Riding Mower

Model No. 74447TE—Serial No. 40000000 and Up

Model No. 74451TE—Serial No. 40000000 and Up

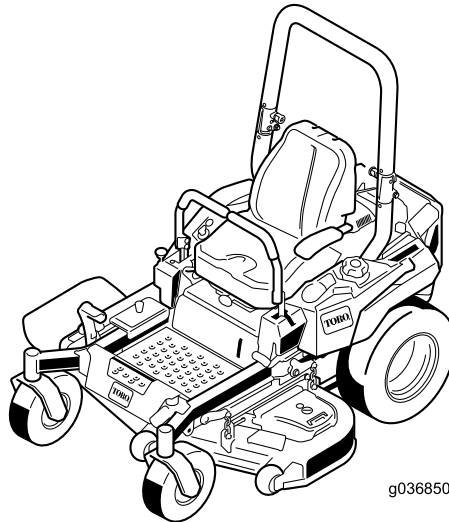

g036850



This product complies with all relevant European directives; for details, please see the separate product specific Declaration of Conformity (DOC) sheet.

This spark ignition system complies with Canadian ICES-002.

▲ WARNING

Removing standard original equipment parts and accessories may alter the warranty, traction, and safety of the machine. Failure to use original Toro parts could cause serious injury or death. Making unauthorized changes to the engine, fuel or venting system, may violate regulations.

Replace all parts including, but not limited to, tires, belts, blades, and fuel system components with original Toro parts.

Important: If you are using a machine with a Toro engine above 1500 m (5,000 ft) for a continuous period, ensure that the High Altitude Kit has been installed so that the engine meets CARB/EPA emission regulations. The High Altitude Kit increases engine performance while preventing spark-plug fouling, hard starting, and increased emissions. Once you have installed the kit, attach the high-altitude label next to the serial decal on the machine. Contact any Authorized Toro Service Dealer to obtain the proper High Altitude Kit and high-altitude label for your machine. To locate a dealer convenient to you, access our website at www.Toro.com or contact our Toro Customer Care Department at the number(s) listed in your Emission Control Warranty Statement.

Remove the kit from the engine and restore the engine to its original factory configuration when running the engine under 1500 m (5,000 ft). Do not operate an engine that has been converted for high-altitude use at lower altitudes; otherwise, you could overheat and damage the engine.

If you are unsure whether or not your machine has been converted for high-altitude use, look for the following label (Figure 3).

NOTE: THE ENGINE ON THIS PRODUCT HAS BEEN MODIFIED FOR USE AT ABOVE 5,000 FEET ELEVATION. IF USING BELOW 5,000 FEET, IT MUST BE REVISED BACK TO ORIGINAL SPECIFICATIONS.

127-99363

decal127-99363

Figure 3

Introduction

This rotary-blade, riding lawn mower is intended to be used by residential homeowners or professional, hired operators. It is designed primarily for cutting grass on well-maintained lawns on residential or commercial properties. It is not designed for cutting brush or for agricultural uses.

Read this information carefully to learn how to operate and maintain your product properly and to avoid injury and product damage. You are responsible for operating the product properly and safely.

You may contact Toro directly at www.Toro.com for product safety and operation training materials, accessory information, help finding a dealer, or to register your product.

Whenever you need service, genuine Toro parts, or additional information, contact an Authorized Service Dealer or Toro Customer Service and have the model and serial numbers of your product ready. Figure 1 identifies the location of the model and serial numbers on the product. Write the numbers in the space provided.

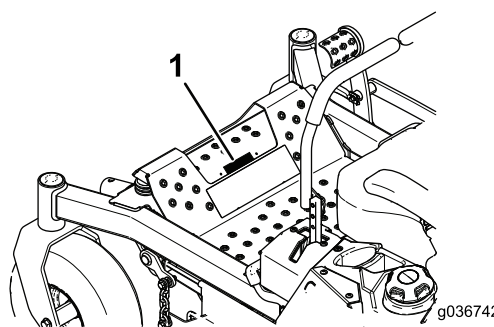

Figure 1

1. Model and serial number location

Model No. _____

Serial No. _____

This manual identifies potential hazards and has safety messages identified by the safety-alert symbol (Figure 2), which signals a hazard that may cause serious injury or death if you do not follow the recommended precautions.



Figure 2

g000502

1. Safety-alert symbol

This manual uses 2 words to highlight information.

Important calls attention to special mechanical information and **Note** emphasizes general information worthy of special attention.

Contents

Safety	4
General Safety.....	4
Slope Indicator	5
Safety and Instructional Decals	6
Product Overview	12
Controls	12
Specifications	14
Before Operation	14
Before Operation Safety.....	14
Recommended Fuel.....	15
Using Stabilizer/Conditioner	15
Filling the Fuel Tank	15
Checking the Engine-Oil Level.....	16
Breaking in a New Machine.....	16
Using the Rollover-Protection System (ROPS).....	16
Think Safety First	17
Using the Safety-Interlock System.....	18
Positioning the Seat	19
Changing the Seat Suspension	19
Using Attachments and Accessories	19
During Operation	19
During Operation Safety	19
Operating the Parking Brake	20
Operating the Mower Blade-Control Switch (PTO)	21
Operating the Throttle.....	21
Operating the Choke.....	21
Operating the Ignition Switch	22
Starting and Shutting Off the Engine.....	22
Using the Motion-Control Levers	23
Driving the Machine	24
Adjusting the Height-of-Cut	25
Adjusting the Anti-Scalp Rollers	26
Stopping the Machine	26
Using the Side Discharge.....	27
Operating Tips	27
After Operation	28
After Operation Safety.....	28
Using the Fuel-Shutoff Valve	28
Using the Drive-Wheel-Release Valves.....	28
Transporting the Machine.....	29
Loading the Machine	30
Maintenance	31
Recommended Maintenance Schedule(s)	31
Pre-Maintenance Procedures	32
Maintenance and Storage.....	32
Releasing the Mower-Deck Curtain	32
Removing the Sheet-Metal Guard	32
Lubrication	34
Greasing the Machine	34
Engine Maintenance	35
Engine Safety.....	35
Servicing the Engine.....	35
Checking the Spark Arrester.....	40
Replacing the Emissions-Air Intake Filter	40
Fuel System Maintenance	40

Safety

This machine has been designed in accordance with EN ISO 5395:2013.

General Safety

This product is capable of amputating hands and feet and of throwing objects. Always follow all safety instructions to avoid serious personal injury.

Using this product for purposes other than its intended use could prove dangerous to you and bystanders.

- Read and understand the contents of this *Operator's Manual* before you start the engine. Ensure that everyone using this product knows how to use it and understands the warnings.
- Do not put your hands or feet near moving components of the machine.
- Do not operate the machine without all guards and other safety protective devices in place and working on the machine.
- Keep clear of any discharge opening. Keep bystanders a safe distance from the machine.
- Keep children out of the operating area. Never allow children to operate the machine.
- Stop the machine and shut off the engine before servicing, fueling, or unclogging the machine.

Improperly using or maintaining this machine can result in injury. To reduce the potential for injury, comply with these safety instructions and always pay attention to the safety-alert symbol, which means Caution, Warning, or Danger—personal safety instruction. Failure to comply with these instructions may result in personal injury or death.

You can find additional items of safety information in their respective sections throughout this manual.

Replacing the Fuel Filter	40
Servicing the Fuel Tank	41
Electrical System Maintenance	41
Electrical System Safety	41
Servicing the Battery	41
Servicing the Fuses	43
Drive System Maintenance	43
Checking the Seat Belt	43
Checking the Roll-Bar Knobs	43
Adjusting the Tracking	44
Checking the Tire Pressure	45
Checking the Wheel Lug Nuts	45
Cooling System Maintenance	45
Cleaning the Engine Screen	45
Brake Maintenance	46
Adjusting the Parking Brake	46
Belt Maintenance	47
Inspecting the Belts	47
Replacing the Mower Belt for Side Discharge Mower Decks	47
Replacing the Hydraulic-Pump-Drive Belt	48
Controls System Maintenance	49
Adjusting the Control-Handle Position	49
Adjusting the Motion-Control Linkage	50
Hydraulic System Maintenance	51
Hydraulic System Safety	51
Servicing the Hydraulic System	51
Changing the Hydraulic-System Filters and Fluid	52
Mower Deck Maintenance	56
Leveling the Mower Deck	56
Servicing the Cutting Blades	57
Removing the Mower Deck	60
Replacing the Grass Deflector	60
Cleaning	61
Cleaning under the Mower	61
Disposing of Waste	61
Storage	61
Cleaning and Storing the Machine	61
Troubleshooting	63
Schematics	65

Slope Indicator

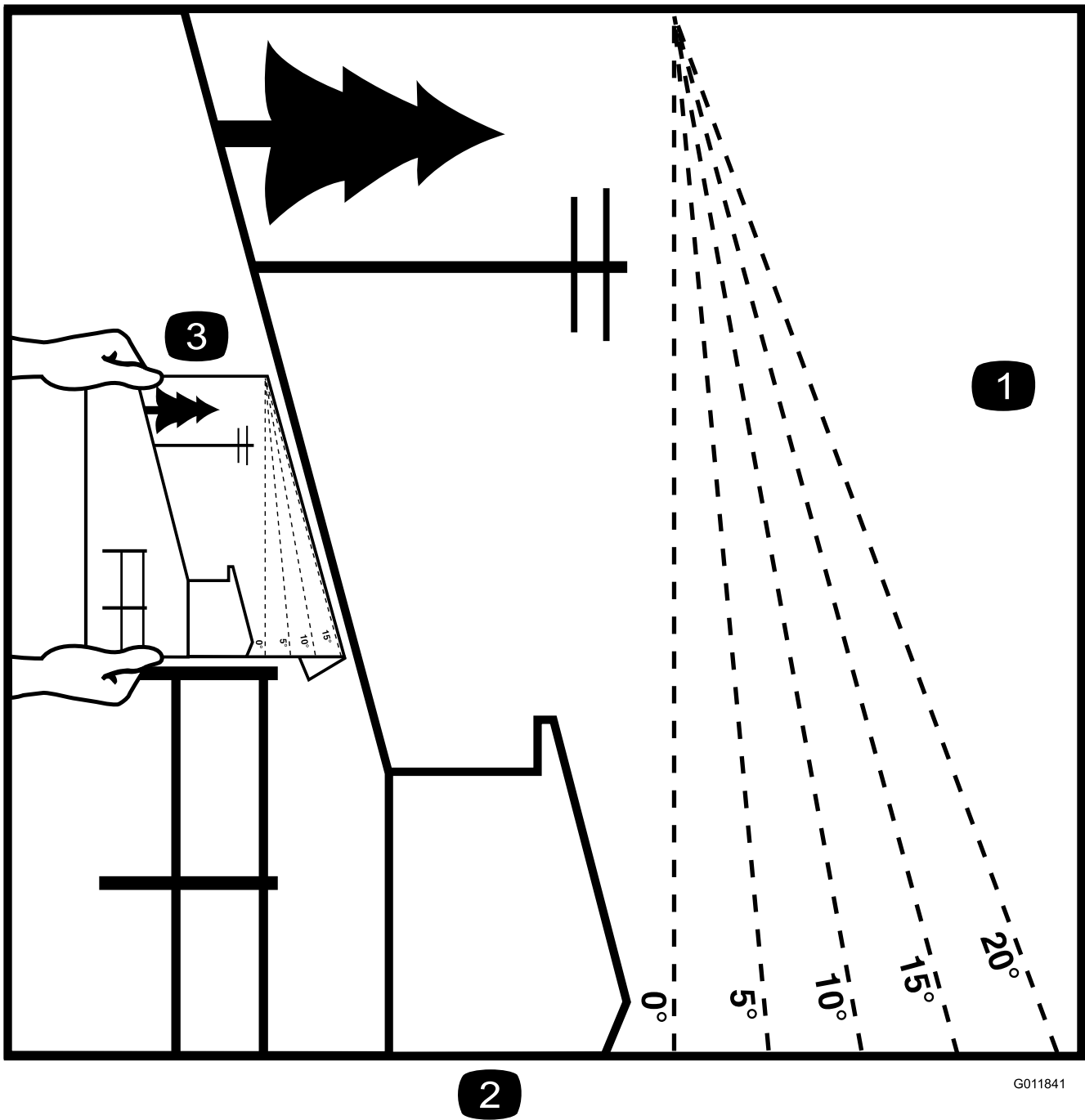

2

G011841

g011841

Figure 4

This page may be copied for personal use.

1. The maximum slope you can safely operate the machine on is **15 degrees**. Use the slope chart to determine the degree of slope of hills before operating. **Do not operate this machine on a slope greater than 15 degrees.** Fold along the appropriate line to match the recommended slope.
2. Align this edge with a vertical surface, a tree, building, fence pole, etc.
3. Example of how to compare slope with folded edge.

Safety and Instructional Decals



Safety decals and instructions are easily visible to the operator and are located near any area of potential danger. Replace any decal that is damaged or lost.

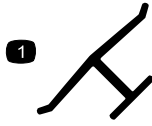

decal0emmarkt

Manufacturer's Mark

1. Indicates the blade is identified as a part from the original machine manufacturer.

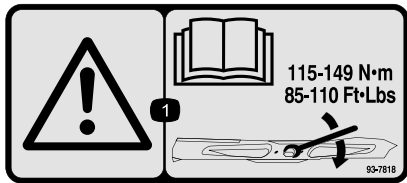

decal93-7818

93-7818

1. Warning—read the *Operator's Manual* for instructions on torquing the blade bolt/nut to 115-149 N·m (85-110 ft-lb).



decal106-5517

106-5517

1. Warning—do not touch the hot surface.

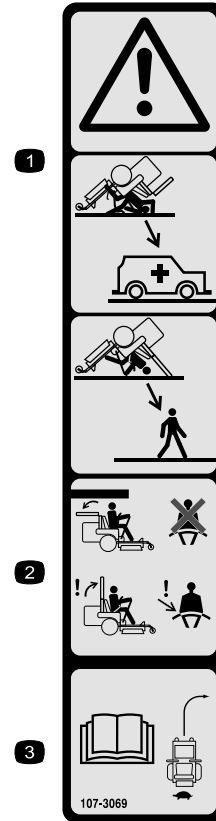

decal107-3069

107-3069

1. Warning—there is no rollover protection when the roll bar is down.
2. To avoid injury or death from a rollover accident, keep the roll bar in the raised and locked position and wear the seat belt. Lower the roll bar only when absolutely necessary; do not wear the seat belt when the roll bar is down.
3. Read the *Operator's Manual*; drive slowly and carefully.

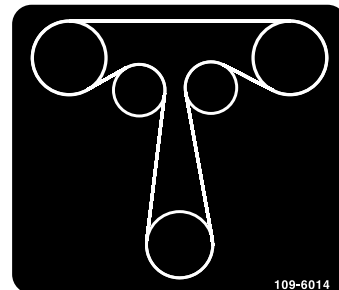

decal109-6014

109-6014

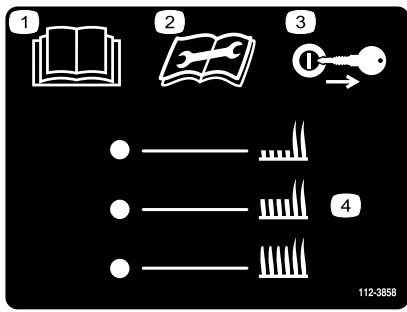

112-3858

decal112-3858

1. Read the *Operator's Manual*.
2. Read the instructions before servicing or performing maintenance.
3. Remove the ignition key before adjusting the height of cut.
4. Height-of-cut settings.

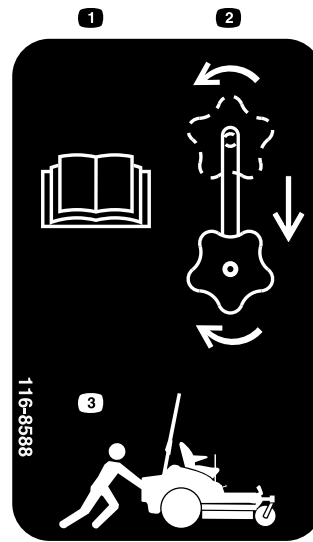

116-8588

decal116-8588

1. Read the Operator's manual.
2. Rotate the drive release knob to loosen, slide the knob, and tighten.
3. Push the machine.

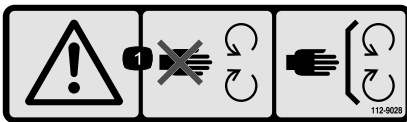

112-9028

decal112-9028

1. Warning—stay away from moving parts; keep all guards in place.

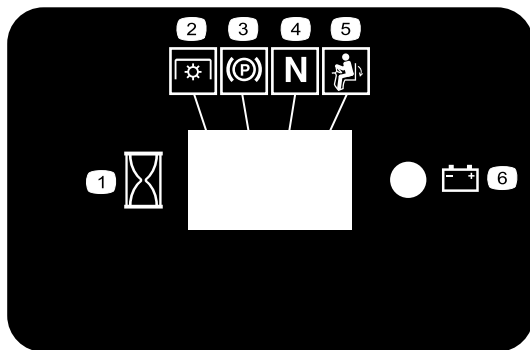

Message Display

decalhourmessagedisplay-116-5610

1. Hour
2. PTO
3. Parking brake
4. Neutral
5. Operator presence switch
6. Battery

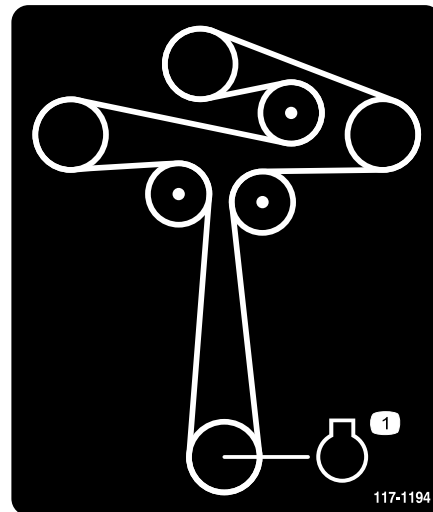

117-1194

decal117-1194

1. Engine



117-3848

decal117-3848

1. Thrown object hazard—keep bystanders a safe distance from the machine.
2. Thrown object hazard, mower—do not operate the machine without deflector, discharge cover, or grass collection system in place.
3. Cutting/dismemberment of hand or foot—stay away from moving parts; keep all guards and shields in place.



126-4363

decal126-4363

1. Cutting/dismemberment hazard, fan and entanglement hazard, belt. Shut off the engine and remove key before adjusting, servicing or cleaning.

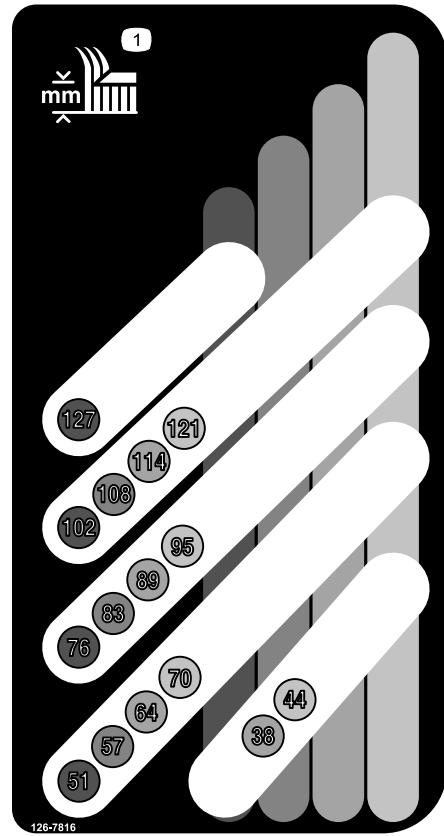

126-7816

decal126-7816

1. Height-of-cut

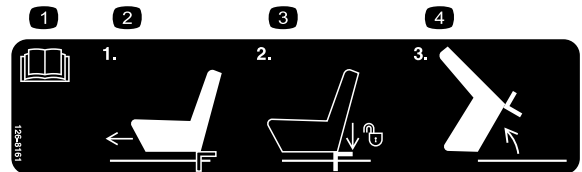

126-8161

decal126-8161

1. Read Operator's manual
2. Slide seat forward
3. Press down on latch to unlock seat
4. Rotate seat

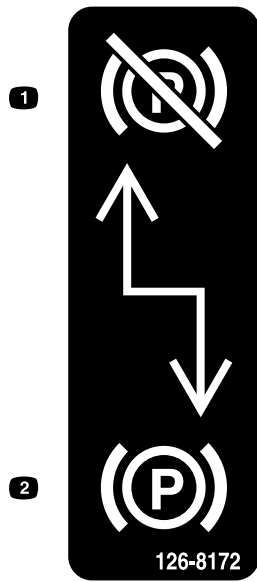

126-8172

decal126-8172

1. Parking brake disengaged
2. Parking brake engaged

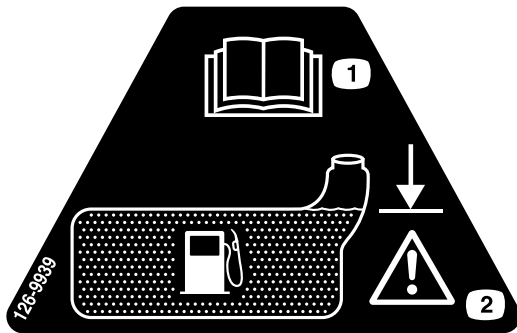

126-9939

decal126-9939

1. Read the Operator's Manual
2. Fill to bottom of filler neck; warning—do not overfill the tank

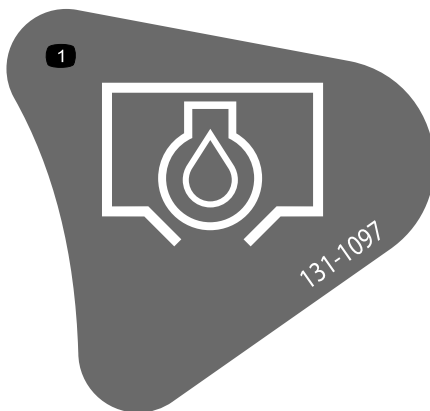

131-1097

decal131-1097

Toro Engines Only

1. Oil drain

**1 SHUT DOWN ENGINE AT FULL THROTTLE
COUPEZ LE MOTEUR À PLEIN RÉGIME**

decal132-0904

Toro Engine Only

1. Shut down engine at full throttle

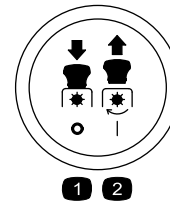

decalptosymbols

PTO Switch Symbols

1. PTO—disengage
2. PTO—engage

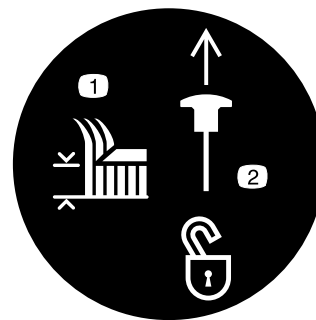

decaltransportlock

Transport Lock

1. Height of cut
2. Pull up to unlock the transport lock

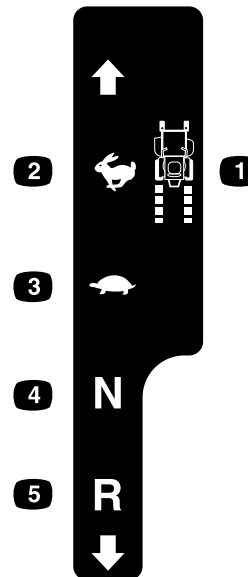

decalmotionctrlh-126-6194

Left Motion Control

1. Machine speed
2. Fast
3. Slow
4. Neutral
5. Reverse

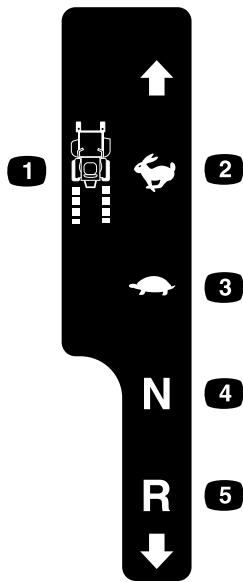

Right Motion Control

- | | |
|------------------|------------|
| 1. Machine speed | 4. Neutral |
| 2. Fast | 5. Reverse |
| 3. Slow | |

decalmotionctrlrh-126-6183

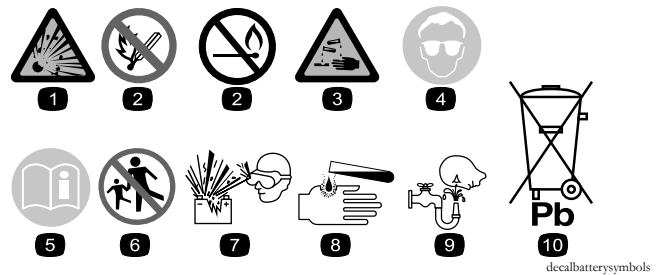

Battery Symbols

Some or all of these symbols are on your battery.

- | | |
|--|---|
| 1. Explosion hazard | 6. Keep bystanders a safe distance from the battery. |
| 2. No fire, open flame, or smoking | 7. Wear eye protection; explosive gases can cause blindness and other injuries. |
| 3. Caustic liquid/chemical burn hazard | 8. Battery acid can cause blindness or severe burns. |
| 4. Wear eye protection. | 9. Flush eyes immediately with water and get medical help fast. |
| 5. Read the <i>Operator's Manual</i> . | 10. Contains lead; do not discard |

decalbatterysymbols

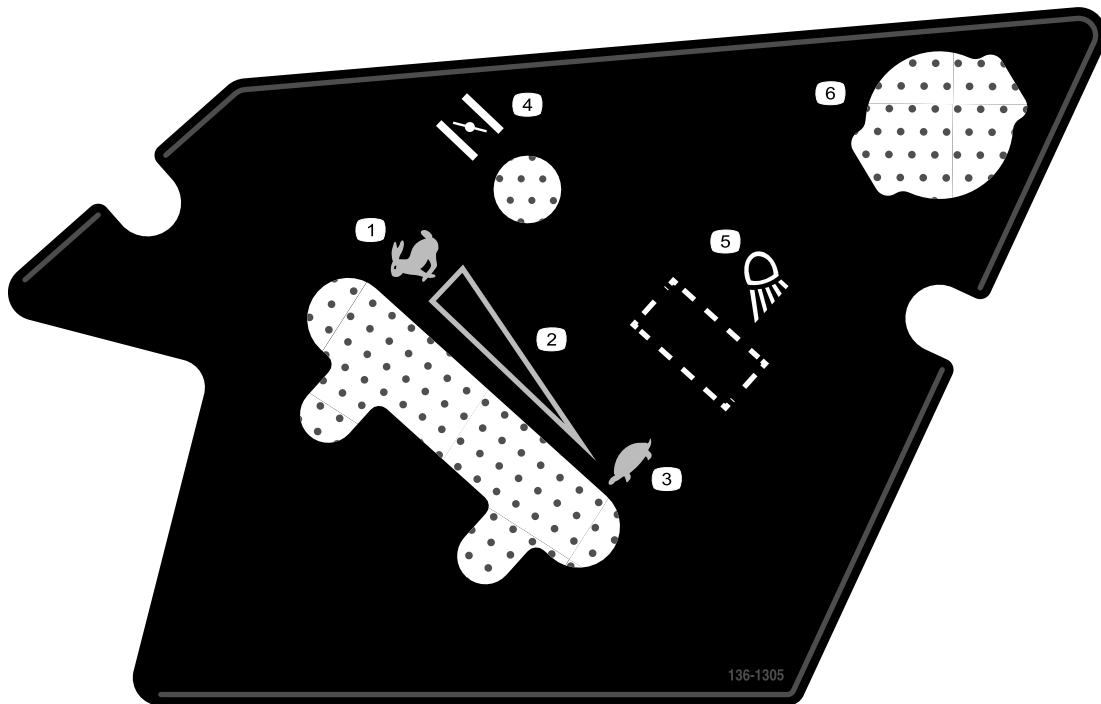

136-1305

- | | |
|--------------------------------|--------------------------|
| 1. Fast | 4. Choke |
| 2. Continuous variable setting | 5. Work light (optional) |
| 3. Slow | 6. Power point |

decal136-1305

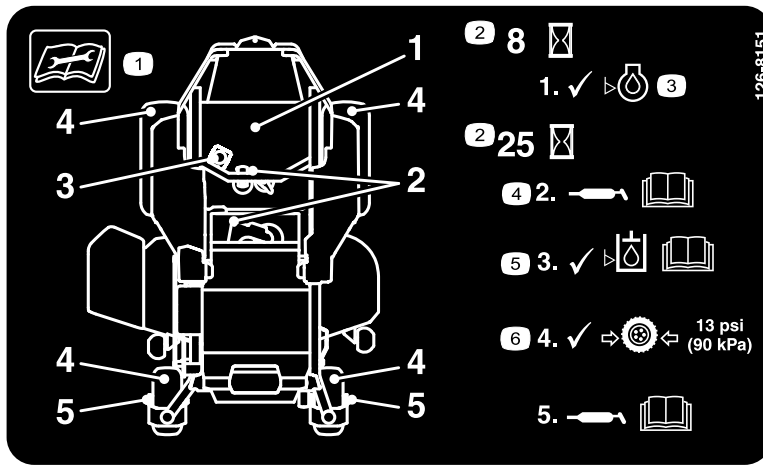

126-8151

decal126-8151

1. Read the instructions before servicing or performing maintenance
2. Time interval
3. Check oil level
4. Refer to the Operator's manual for grease instructions
5. Check hydraulic oil level and refer to the Operator's manual for further instructions
6. Check tire pressure

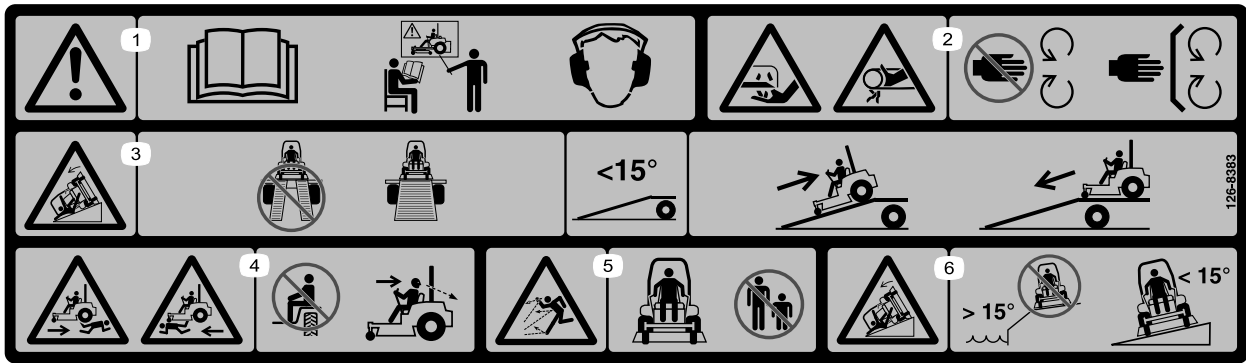

126-8383

decal126-8383

1. Warning-Read the Operator's Manual. Do Not operate this machine unless you are trained. Wear hearing protection.
2. Cutting and pinching hazard - keep hands and feet away from moving parts; keep all guards and shields in place.
3. Ramp hazard - when loading onto a trailer, do not use dual ramps; only use a singular ramp wide enough for the machine and that has an incline less than 15 degrees; back up the ramp (in reverse) and drive forward off the ramp.
4. Bodily harm hazard - look behind you when mowing in reverse.
5. Thrown object hazard - keep bystanders away.
6. Tipping hazard on slopes - do not use on slopes near open water; do not use on slopes greater than 15 degrees.

Product Overview

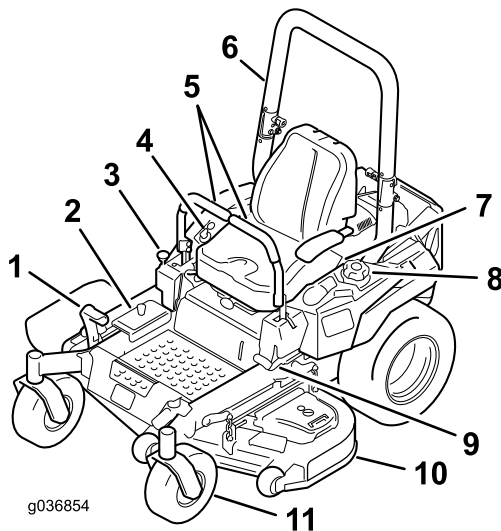

Figure 5

- | | |
|----------------------------------|------------------------|
| 1. Height-of-cut deck-lift pedal | 7. Seat belt |
| 2. Height-of-cut positions | 8. Fuel cap |
| 3. Transport lock | 9. Parking-brake lever |
| 4. Controls | 10. Mower deck |
| 5. Motion-control levers | 11. Caster wheel |
| 6. Roll bar | |

Controls

Become familiar with all the controls before you start the engine and operate the machine (Figure 5 and Figure 6).

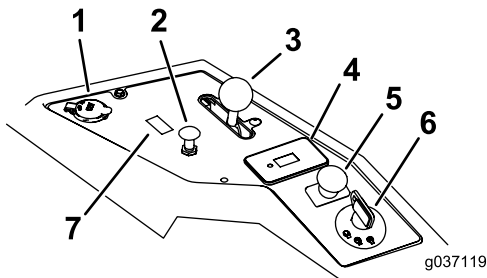

Figure 6

- | | |
|---------------------|---|
| 1. Power port | 5. PTO Switch |
| 2. Choke control | 6. Ignition switch |
| 3. Throttle control | 7. Switch position for optional light kit |
| 4. Hour meter | |

Ignition Switch

Use this switch to start the mower engine. It has 3 positions: START, RUN, and OFF.

Choke Control

Use the choke to start a cold engine. Pull the choke knob up to engage it. Push the choke knob down to disengage it (Figure 6).

Throttle Control

The throttle controls the engine speed, and it has a continuous-variable setting from the SLOW to FAST position (Figure 6).

Blade-Control Switch (Power Takeoff)

The blade-control switch (PTO) engages and disengages power to the mower blades (Figure 6).

Hour Meter

The hour meter records the number of hours the engine has operated. It operates when the engine is running. Use these times for scheduling regular maintenance (Figure 6).

Safety-Interlock Indicators

There are symbols on the hour meter that indicate with a black triangle that the interlock component is positioned correctly (Figure 7).

Battery-Indicator Light

If you turn the ignition key to the ON position for a few seconds, the battery voltage displays in the area where the hours are normally displayed.

The battery light turns on when the ignition is turned on and when the charge is below the correct operating level (Figure 7).

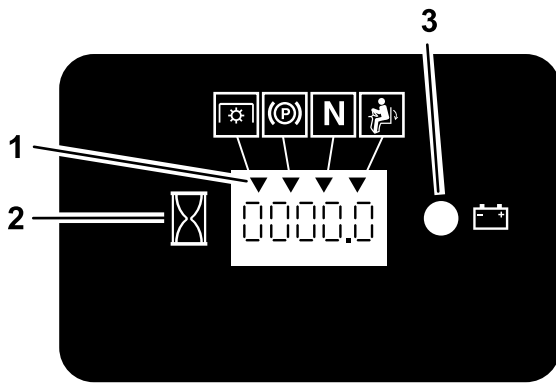

g187133

Figure 7

1. Safety-interlock symbols
2. Hour meter
3. Battery light

Motion-Control Levers

Use the motion-control levers to drive the machine forward, reverse, and turn either direction.

Neutral-Lock Position

Use the NEUTRAL-LOCK position with the safety-interlock system to determine the NEUTRAL position.

Fuel-Shutoff Valve

Close the fuel-shutoff valve (behind the seat) when transporting or storing the mower.

Attachments/Accessories

A selection of Toro approved attachments and accessories is available for use with the machine to enhance and expand its capabilities. Contact your Authorized Service Dealer or Distributor or go to www.Toro.com for a list of all approved attachments and accessories.

Specifications

Note: Specifications and design are subject to change without notice.

Width—Side Discharge Mower Decks:

	122cm mower deck	132cm mower deck
Without mower deck	121 cm (47-1/2 inches)	124 cm (49 inches)
Deflector up	133 cm (53 inches)	144 cm (56-3/4 inches)
Deflector down	160 cm (63-1/4 inches)	171 cm (67-1/4 inches)

Length—Side Discharge Mower Decks:

	122cm mower deck	132cm mower deck
Length	208 cm (82 inches)	208 cm (82 inches)

Height:

Roll Bar - Up	Roll Bar - Down
179 cm (70-1/2 inches)	125 cm (49 inches)

Weight:

Machines	Weight
122cm side discharge machines	849-937 lb (385-425 kg)
132cm side discharge machines	862-957 lb (391-434 kg)

Operation

Note: Determine the left and right sides of the machine from the normal operating position.

Before Operation

Before Operation Safety

General Safety

- Never allow children or untrained people to operate or service the machine. Local regulations may restrict the age of the operator. The owner is responsible for training all operators and mechanics.
- Become familiar with the safe operation of the equipment, operator controls, and safety signs.
- Know how to stop the machine and engine quickly.
- Check that operator-presence controls, safety switches, and shields are attached and functioning properly. Do not operate the machine unless they are functioning properly.
- Before mowing, always inspect the machine to ensure that the blades, blade bolts, and cutting assemblies are in good working condition. Replace worn or damaged blades and bolts in sets to preserve balance.

- Inspect the area where you will use the machine and remove all objects that the machine could throw.
- Evaluate the terrain to determine the appropriate equipment and any attachments or accessories required to operate the machine properly and safely.

Fuel Safety

- To avoid personal injury or property damage, use extreme care in handling fuel. Fuel vapors are flammable and explosive.
- Extinguish all cigarettes, cigars, pipes, and other sources of ignition.
- Use only an approved fuel container.
- Do not remove the fuel cap or add fuel to the fuel tank while the engine is running or while hot.
- Do not refuel the machine indoors.
- Do not store the machine or fuel container where there is an open flame, spark, or pilot light, such as on a water heater or on other appliances.
- Do not fill containers inside a vehicle or on a truck or trailer bed with a plastic liner. Always place containers on the ground, away from your vehicle before filling.
- Remove the equipment from the truck or trailer and refuel it while it is on the ground. If this is not possible,

then refuel from a portable container rather than a fuel-dispenser nozzle.

- Do not operate the machine without the entire exhaust system in place and in proper working condition.
- Keep the fuel-dispenser nozzle in contact with the rim of the fuel tank or container opening at all times until fueling is complete. Do not use a nozzle lock-open device.
- If you spill fuel on your clothing, change your clothing immediately. Wipe up any fuel that spills.
- Never overfill the fuel tank. Replace the fuel cap and tighten it securely.
- Store fuel in an approved container and keep it out of the reach of children. Never buy more than a 30-day supply of fuel.
- Do not fill the fuel tank completely full. Add fuel to the fuel tank until the level is 6 to 13 mm (1/4 to 1/2 inch) below the bottom of the filler neck. This empty space in the tank allows fuel to expand.
 - Avoid prolonged breathing of vapors.
 - Keep your face away from the nozzle and gas tank opening.
 - Avoid contact with skin; wash off spills with soap and water.

Recommended Fuel

- For best results, use only clean, fresh (less than 30 days old), unleaded gasoline with an octane rating of 87 or higher ((R+M)/2 rating method).
- **Ethanol:** Gasoline with up to 10% ethanol (gasohol) or 15% MTBE (methyl tertiary butyl ether) by volume is acceptable. Ethanol and MTBE are not the same. Gasoline with 15% ethanol (E15) by volume is not approved for use. **Never use gasoline that contains more than 10% ethanol by volume**, such as E15 (contains 15% ethanol), E20 (contains 20% ethanol), or E85 (contains up to 85% ethanol). Using unapproved gasoline may cause performance problems and/or engine damage which may not be covered under warranty.
- **Do not** use gasoline containing methanol.
- **Do not** store fuel either in the fuel tank or fuel containers over the winter unless you use a fuel stabilizer.
- **Do not** add oil to gasoline.

Using Stabilizer/Conditioner

Use a fuel stabilizer/conditioner in the machine to provide the following benefits:

- Keeps fuel fresh during storage of 90 days or less (drain the fuel tank when storing the machine for more than 90 days)
- Cleans the engine while it runs
- Eliminates gum-like varnish buildup in the fuel system, which causes hard starting

Important: Do not use fuel additives containing methanol or ethanol.

Add the correct amount of fuel stabilizer/conditioner to the fuel.

Note: A fuel stabilizer/conditioner is most effective when mixed with fresh fuel. To minimize the chance of varnish deposits in the fuel system, use fuel stabilizer at all times.

Filling the Fuel Tank

1. Park the machine on level ground.
2. Shut off the engine and engage the parking brake.
3. Clean around the fuel-tank cap.
4. Fill the fuel tank to the bottom of the filler neck (Figure 8).

Note: Do not fill the fuel tank completely full. The empty space in the tank allows the gasoline to expand.

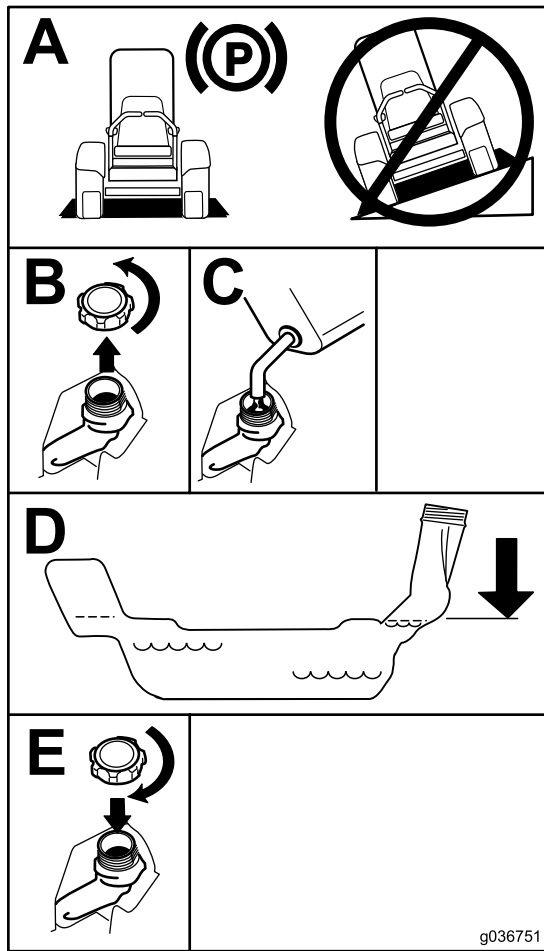

Figure 8

g036751

Using the Rollover-Protection System (ROPS)

⚠ WARNING

To avoid injury or death from rollover: keep the roll bar in the fully raised locked position and use the seat belt.

Ensure that the seat is secured to the machine.

⚠ WARNING

There is no rollover protection when the roll bar is in the down position.

- Lower the roll bar only when absolutely necessary.
- Do not wear the seat belt when the roll bar is in the down position.
- Drive slowly and carefully.
- Raise the roll bar as soon as clearance permits.
- Check carefully for overhead clearances (i.e., branches, doorways, electrical wires) before driving under any objects and do not contact them.

Important: Lower the roll bar only when absolutely necessary.

1. To lower the roll bar, apply forward pressure to the upper part of the roll bar.
2. Pull both knobs out and rotate them 90 degrees so they are not engaged (Figure 9).
3. Lower the roll bar to the down position (Figure 9).

Checking the Engine-Oil Level

Before you start the engine and use the machine, check the oil level in the engine crankcase; refer to [Checking the Engine-Oil Level](#) (page 36).

Breaking in a New Machine

New engines take time to develop full power. Mower decks and drive systems have higher friction when new, placing additional load on the engine. Allow 40 to 50 hours of break-in time for new machines to develop full power and best performance.

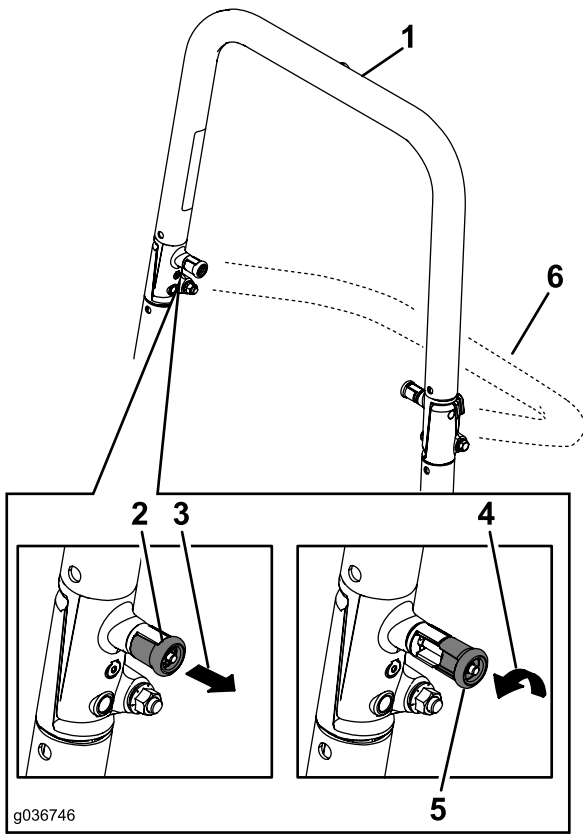

Figure 9

1. Roll bar in the upright position
2. ROPS knob in the latched position
3. Pull the ROPS knob out.
4. Rotate the ROPS knob 90 degrees.
5. ROPS knob in the unlatched position
6. Roll bar in the folded position

4. To raise the roll bar, raise the roll bar to the operating position and rotate the knobs until they move partially into the grooves (Figure 9).
5. Raise the roll bar to the full upright position while pushing on the upper roll bar so that the pins snap into position when the holes align with the pins (Figure 9).

Important: Always use the seat belt with the roll bar in the raised position.

6. Push on the roll bar and ensure that both pins are engaged.

Think Safety First

Please read all safety instructions and symbols in the safety section. Knowing this information could help you or bystanders avoid injury.

⚠ DANGER

Operating the machine on wet grass or steep slopes can cause sliding and loss of control.

- Do not operate on slopes greater than 15 degrees.
- Reduce speed and use extreme caution on slopes.
- Do not operate the machine near water.

⚠ DANGER

Wheels dropping over edges can cause rollovers, which may result in serious injury, death, or drowning.

Do not operate the machine near drop-offs.

⚠ DANGER

Operating the machine while the roll bar is down may lead to serious injury or death in the event of a rollover.

Always keep the roll bar in the fully raised and locked position and use the seat belt.

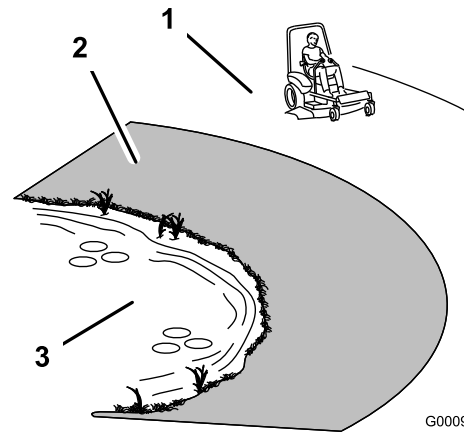

Figure 10

1. Safe Zone—use the machine here on slopes less than 15 degrees or flat areas.
2. Danger Zone—use a walk-behind mower and/or a hand trimmer on slopes greater than 15 degrees and near drop-offs or water.
3. Water

⚠ CAUTION

This machine produces sound levels in excess of 85 dBA at the operator's ear and can cause hearing loss through extended periods of exposure.

Wear hearing protection when operating this machine.

Use protective equipment for your eyes, ears, hands, feet, and head.

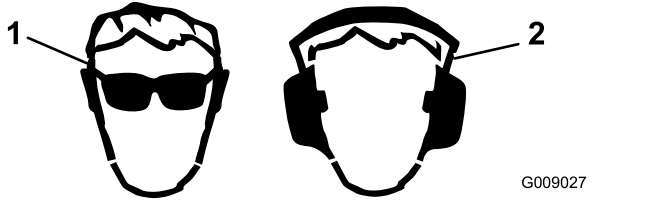

Figure 11

1. Wear eye protection.
2. Wear hearing protection.

Using the Safety-Interlock System

⚠ WARNING

If safety-interlock switches are disconnected or damaged, the machine could operate unexpectedly causing personal injury.

- Do not tamper with the interlock switches.
- Check the operation of the interlock switches daily, and replace any damaged switches before operating the machine.

Understanding the Safety-Interlock System

The safety-interlock system is designed to prevent the engine from starting unless:

- The parking brake is engaged.
- The blade-control switch (PTO) is disengaged.
- The motion-control levers are in the NEUTRAL-LOCK position.

The safety-interlock system is also designed to shut off the engine when the traction controls are moved from the locked position with the parking brake engaged or if you rise from the seat when the PTO is engaged.

The hour meter has symbols to notify the user when the interlock component is in the correct position. When the component is in the correct position, a triangle lights up in the corresponding square.

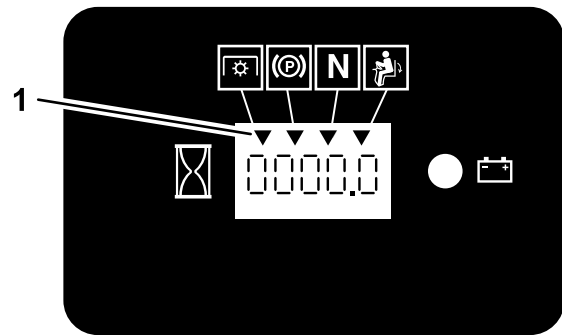

Figure 12

1. Triangles light up when the interlock components are in the correct position

Testing the Safety-Interlock System

Service Interval: Before each use or daily

Test the safety-interlock system before you use the machine each time. If the safety system does not operate as described below, have an Authorized Service Dealer repair the safety system immediately.

1. Sitting on the seat, engage the parking brake and move the blade-control switch (PTO) to the ON position. Try starting the engine; the engine should not start.
2. Sitting on the seat, engage the parking brake and move the blade-control switch (PTO) to the OFF position. Move either motion-control lever (out of the NEUTRAL-LOCK position). Try starting the engine; the engine should not start. Repeat for the other control lever.
3. Sitting on the seat, engage the parking brake, move the blade-control switch (PTO) to the OFF position, and move the motion-control levers to the NEUTRAL-LOCK position. Now start the engine. While the engine is running, disengage the parking brake, engage the blade-control switch (PTO), and rise slightly from the seat; the engine should shut off.
4. Sitting on the seat, engage the parking brake, move the blade-control switch (PTO) to the OFF position, and move the motion-control levers to the NEUTRAL-LOCK position. Now start the engine. While the engine is running, center either motion control and move (forward or reverse); the engine should shut off. Repeat for other motion control.
5. Sitting on the seat, disengage the parking brake, move the blade-control switch (PTO) to the OFF position, and move the motion-control levers to the NEUTRAL-LOCK position. Try starting the engine; the engine should not start.

Positioning the Seat

The seat can move forward and backward (Figure 13). Position the seat where you have the best control of the machine and are most comfortable.

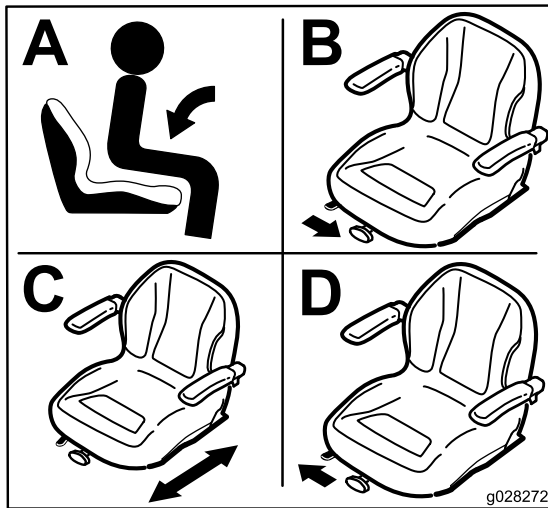

Figure 13

Changing the Seat Suspension

The seat is adjustable to provide a smooth and comfortable ride. Position the seat where you are most comfortable.

To adjust it, turn the knob in front either direction to provide the best comfort (Figure 14).

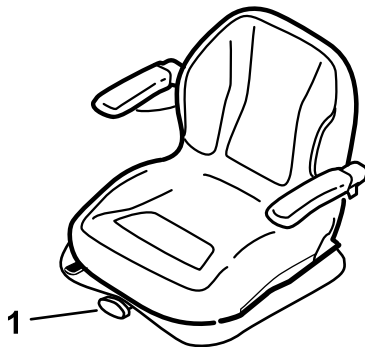

Figure 14

1. Seat-suspension knob

Using Attachments and Accessories

Use only Toro approved attachments and accessories.

If more than one accessory-mount kit (i.e. bucket kit or universal mount kit) is added to any of the 4 locations shown

in Figure 15, add a front-weight kit. Contact your authorized service dealer for the front-weight kit.

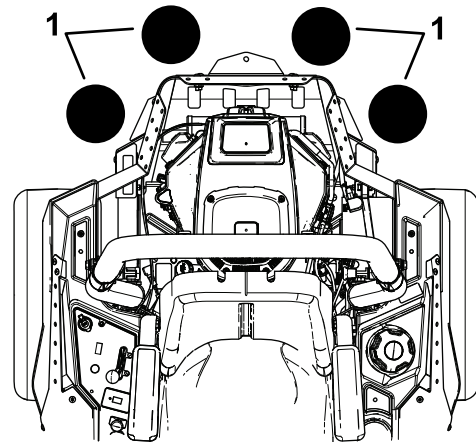

Figure 15

1. Add a front-weight kit when 2 or more accessory-mount kits are installed at these positions.

During Operation

During Operation Safety

General Safety

- The owner/operator can prevent and is responsible for accidents that may cause personal injury or property damage.
- Wear appropriate clothing, including eye protection; slip-resistant, substantial footwear; and hearing protection. Tie back long hair and do not wear jewelry.
- Do not operate the machine while ill, tired, or under the influence of alcohol or drugs.
- Never carry passengers on the machine and keep bystanders and pets away from the machine during operation.
- Operate the machine only in good visibility to avoid holes or hidden hazards.
- Avoid mowing on wet grass. Reduced traction could cause the machine to slide.
- Ensure that all drives are in neutral, the parking brake is engaged, and you are in the operating position before you start the engine.
- Keep your hands and feet away from the cutting units. Keep clear of the discharge opening at all times.
- Look behind and down before backing up to be sure of a clear path.
- Use care when approaching blind corners, shrubs, trees, or other objects that may obscure your vision.

- Do not mow near drop-offs, ditches, or embankments. The machine could suddenly roll over if a wheel goes over the edge or if the edge gives way.
- Stop the blades whenever you are not mowing.
- Stop the machine and inspect the blades after striking an object or if there is an abnormal vibration in the machine. Make all necessary repairs before resuming operation.
- Slow down and use caution when making turns and crossing roads and sidewalks with the machine. Always yield the right-of-way.
- Disengage the drive to the cutting unit and shut off the engine before adjusting the height of cut (unless you can adjust it from the operating position).
- Never run an engine in an area where exhaust gases are enclosed.
- Never leave a running machine unattended.
- Before leaving the operating position (including to empty the catchers or to unclog the chute), do the following:
 - Stop the machine on level ground.
 - Disengage the power take-off and lower the attachments.
 - Engage the parking brake.
 - Shut off the engine and remove the key.
 - Wait for all moving parts to stop.
- Do not operate the machine when there is the risk of lightning.
- Do not use the machine as a towing vehicle.
- Do not change the governor speed or overspeed the engine.
- Use accessories and attachments approved by Toro only.
- Avoid turning the machine on slopes. If you must turn the machine, turn it slowly and gradually downhill, if possible.
- Do not turn the machine sharply. Use care when reversing the machine.
- Use extra care while operating the machine with attachments; they can affect the stability of the machine.

Operating the Parking Brake

Always engage the parking brake when you stop the machine or leave it unattended.

Engaging the Parking Brake

⚠ WARNING

The parking brake may not hold the machine parked on a slope and could cause personal injury or property damage.

Do not park on slopes unless the wheels are chocked or blocked.

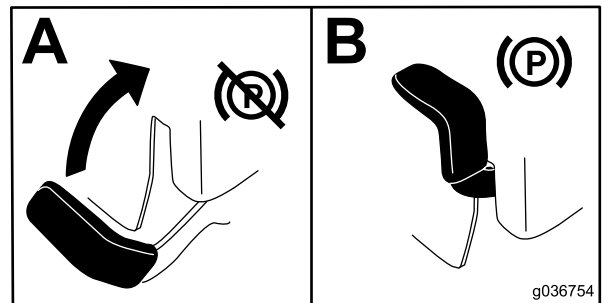

Figure 16

Rollover Protection System (ROPS) Safety

- **Do not** remove the roll bar from the machine.
- Ensure that the seat belt is attached and that you can release it quickly in an emergency.
- Always wear your seat belt when the roll bar is up.
- Check carefully for overhead obstructions and do not contact them.
- Keep the roll bar in safe operating condition by thoroughly inspecting it periodically for damage and keeping all the mounting fasteners tight.
- Replace a damaged roll bar. Do not repair or alter it.

Slope Safety

- Slow down the machine and use extra care on hillsides. Travel up and down on hillsides. Turf conditions can affect the stability of the machine.

Disengaging the Parking Brake

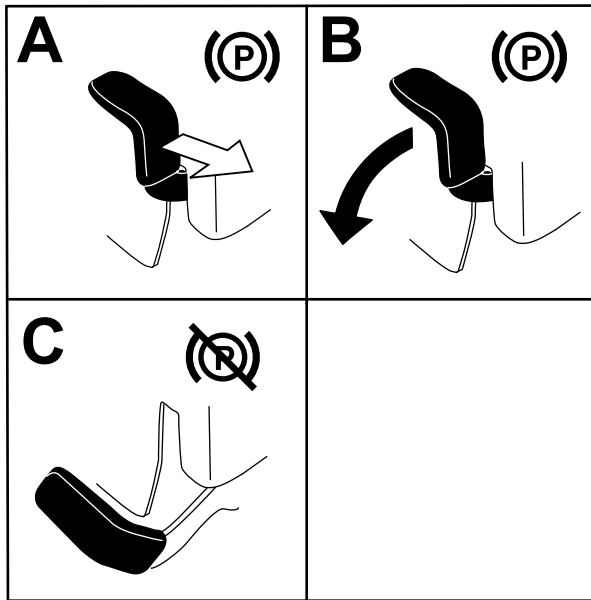

Figure 17

g192635

Operating the Mower Blade-Control Switch (PTO)

The blade-control switch (PTO) starts and stops the mower blades and any powered attachments.

Engaging the Blade-Control Switch (PTO)

Note: Engaging the blade-control switch (PTO) with the throttle position at half or less causes excessive wear to the drive belts.

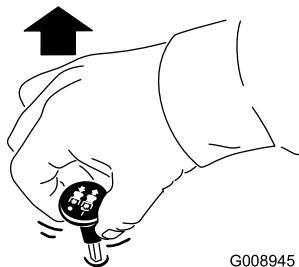
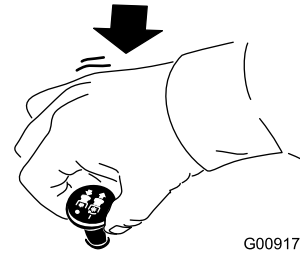

Figure 18

G008945

g008945

Disengaging the Blade-Control Switch (PTO)



G009174

g009174

Figure 19

Operating the Throttle

You can move the throttle control between the FAST and SLOW positions (Figure 20).

Always use the FAST position when turning on the mower deck with the blade-control switch (PTO).

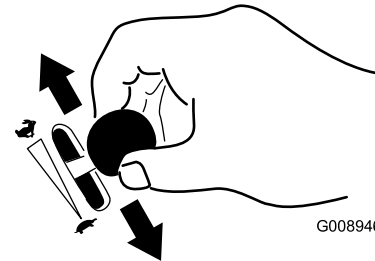

G008946

g008946

Figure 20

Operating the Choke

Use the choke to start a cold engine.

1. If the engine is cold, use the choke to start the engine.
2. Pull up the choke knob to engage the choke before using the ignition switch (Figure 21).
3. Push down the choke knob to disengage the choke after starting the engine (Figure 21).

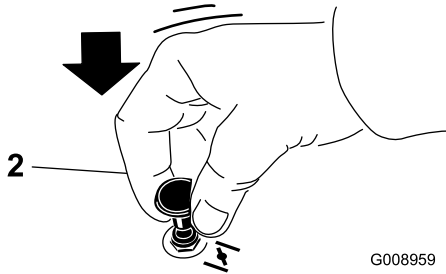
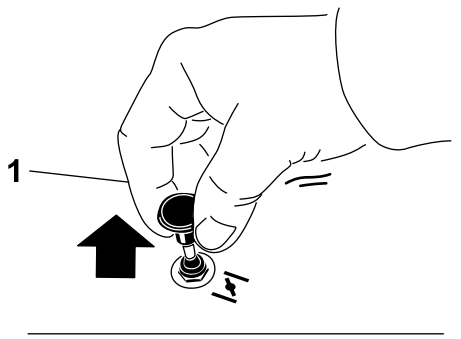

Figure 21

G008959

g008959

1. ON position

2. OFF position

Operating the Ignition Switch

1. Turn the ignition key to the START position (Figure 22).

Note: When the engine starts, release the key.

Important: Do not engage the starter for more than 5 seconds at a time. If the engine fails to start, wait 15 seconds between attempts. Failure to follow these instructions can burn out the starter motor.

Note: You may need multiple attempts to start the engine when you start it the first time after the fuel system has been without fuel completely.

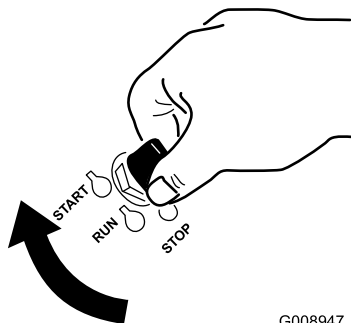

Figure 22

G008947

g008947

2. Turn the ignition key to the STOP position to shut off the engine.

Starting and Shutting Off the Engine

Starting the Engine

1. Raise the roll bar up and lock into place, sit on the seat, and fasten the seat belt.
2. Move the motion controls to the NEUTRAL-LOCK position.
3. Engage the parking brake; refer to [Engaging the Parking Brake \(page 20\)](#).
4. Move the blade-control switch (PTO) to the OFF position (Figure 23).
5. Move the throttle lever midway between the SLOW and FAST positions.

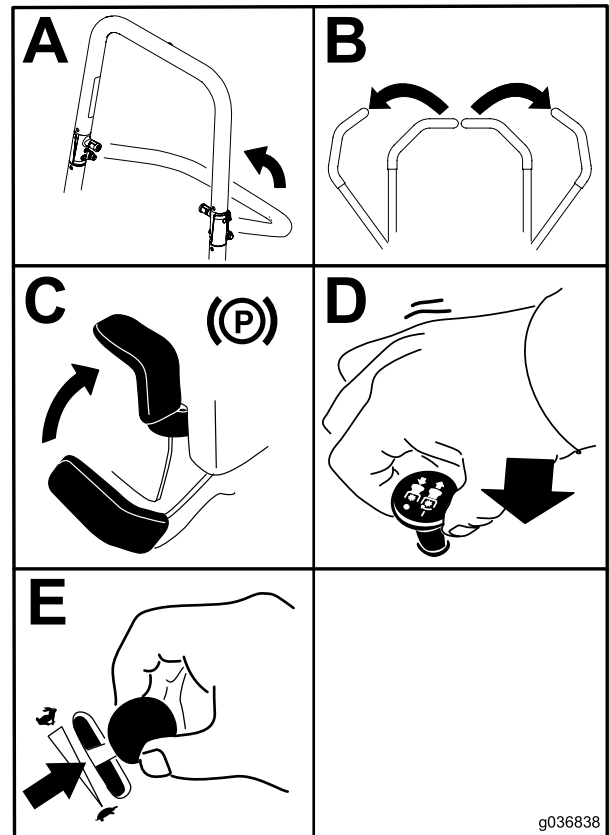

Figure 23

g036838

g036838

6. Turn the ignition key to the START position (Figure 24).

Note: When the engines starts, release the key.

Important: Do not engage starter for more than 5 seconds at a time. If the engine fails to start allow a 15-second cool-down period between attempts. Failure to follow these instructions can burn out the starter motor.

Note: Additional starting cycles may be required when starting the engine for the first time after the fuel system has been without fuel completely.

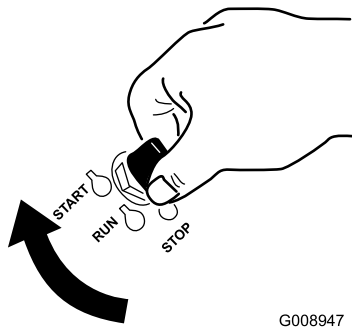

G008947

g008947

Figure 24

Important: Make sure that the fuel-shutoff valve is closed before transporting or storing the machine, as fuel leakage may occur. Engage the parking brake before transporting. Make sure that you remove the key as the fuel pump may run and cause the battery to lose charge.

Using the Motion-Control Levers

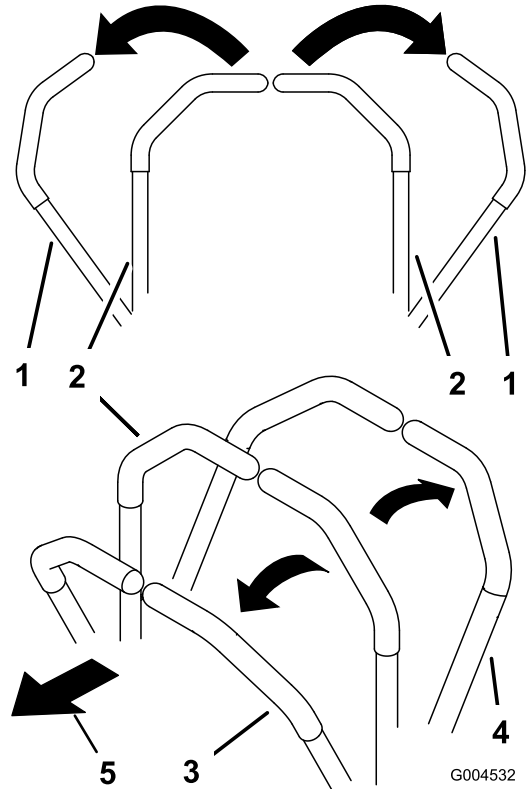

G004532

c:\data\documentum\checkout\g004532

Figure 26

- 1. Motion-control lever—NEUTRAL-LOCK position
- 2. Center, unlocked position
- 3. Forward
- 4. Backward
- 5. Front of machine

Shutting Off the Engine

CAUTION

Children or bystanders may be injured if they move or attempt to operate the machine while it is unattended.

Always remove the ignition key and engage the parking brake when leaving the machine unattended, even if just for a few minutes.

Move the throttle to the FAST position and turn the switch to the OFF position.

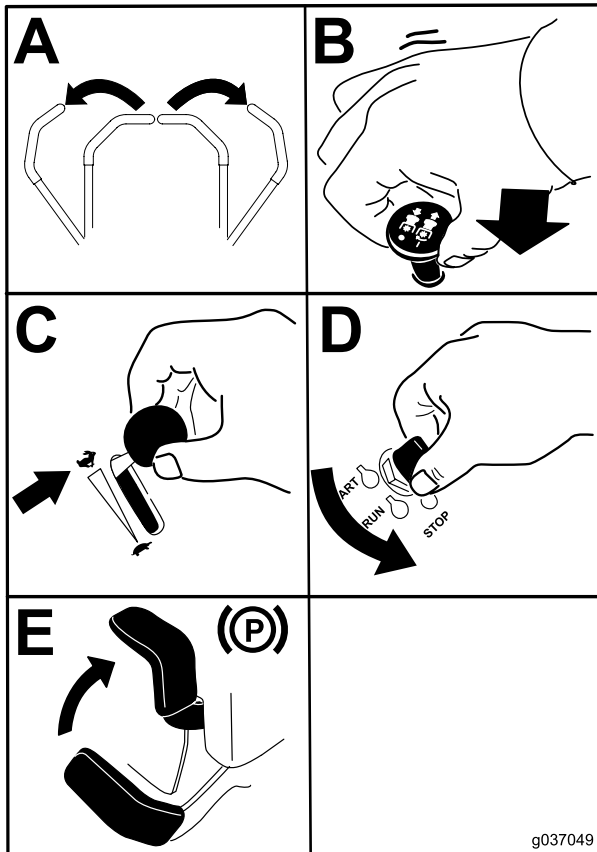

g037049

g037049

Figure 25

Driving the Machine

The drive wheels turn independently, powered by hydraulic motors on each axle. You can turn 1 side in reverse while you turn the other forward, causing the machine to spin rather than turn. This greatly improves the machine maneuverability but may require time for you to adapt to how it moves.

The throttle control regulates the engine speed as measured in rpm (revolutions per minute). Place the throttle control in the FAST position for best performance. Always operate in the full throttle position when mowing.

⚠ CAUTION

Machine can spin very rapidly. Operator may lose control of machine and cause personal injury or damage to machine.

- Use caution when making turns.
- Slow the machine down before making sharp turns.

Driving Forward

Note: The engine stops when you move the traction-control with the parking brake engaged.

To stop, pull the motion-control levers to the NEUTRAL position.

1. Disengage the parking brake; refer to [Disengaging the Parking Brake \(page 21\)](#).
2. Move the levers to the center, unlocked position.
3. To go forward, slowly push the motion-control levers forward ([Figure 27](#)).

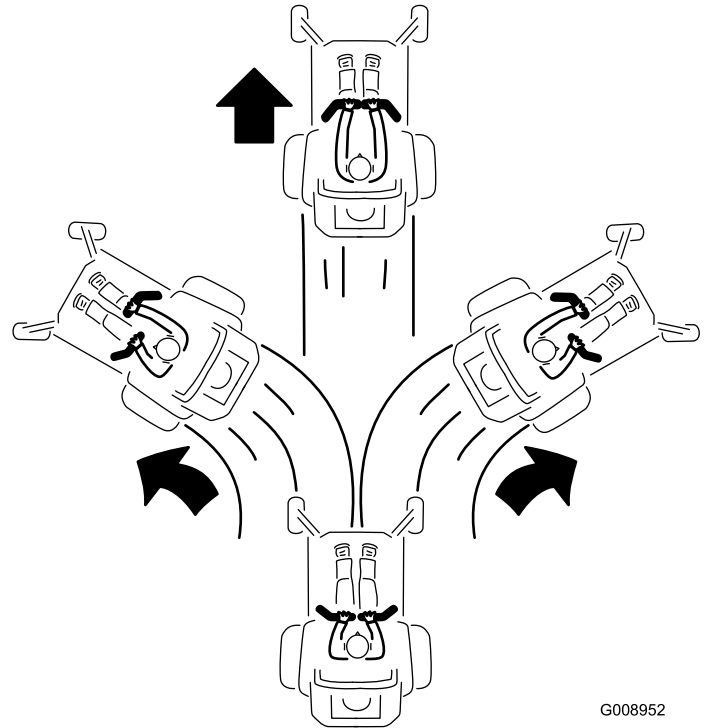

Figure 27

G008952

g008952

Driving Backward

1. Move the levers to the center, unlocked position.
2. To go backward, slowly pull the motion-control levers rearward (Figure 28).

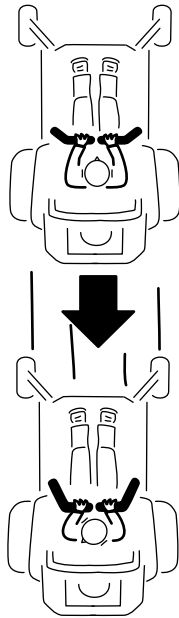

G008953

g008953

Figure 28

Adjusting the Height-of-Cut

Using the Transport Lock

The transport lock has 2 positions, and is used with the deck-lift pedal. There is a LOCK position and an UNLOCK position for the transport position of the mower deck (Figure 29).

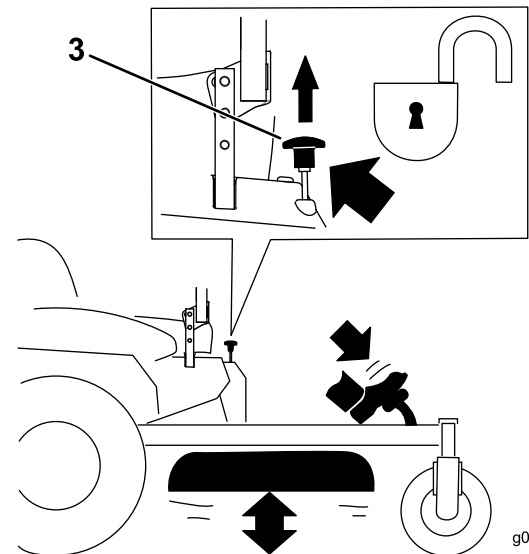
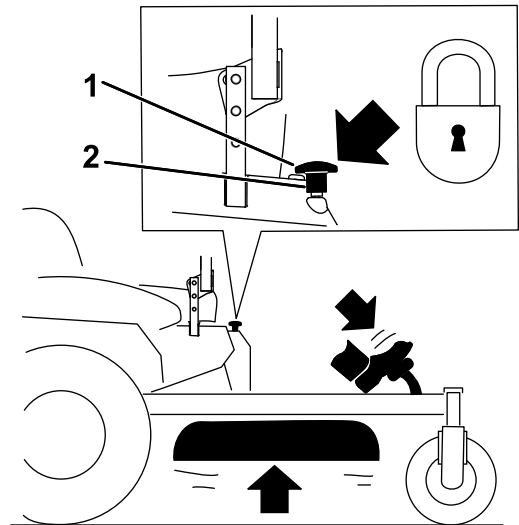

g037050

g037050

Figure 29

Transport-Lock Positions

1. Transport lock knob
2. LOCK position—The mower deck locks into the transport position.
3. UNLOCK position—The mower deck does not lock into the transport position.

Adjusting the Height-of-Cut Pin

Adjust the height-of-cut from 38 to 127 mm (1-1/2 to 5 inches) in 6 mm (1/4 inch) increments by moving the height-of-cut pin into different hole locations.

1. Move the transport lock to the LOCK position.
2. Push on the deck-lift pedal with your foot and raise the mower deck to the TRANSPORT position (also the 127 mm or 5 inch cutting-height position) as shown in [Figure 30](#).
3. To adjust, remove the pin from the height-of-cut bracket (Figure 30).
4. Select a hole in the height-of-cut bracket corresponding to the height-of-cut desired, and insert the pin (Figure 30).
5. Push on the deck lift, pull up on the transport lock knob, and slowly lower the mower deck.

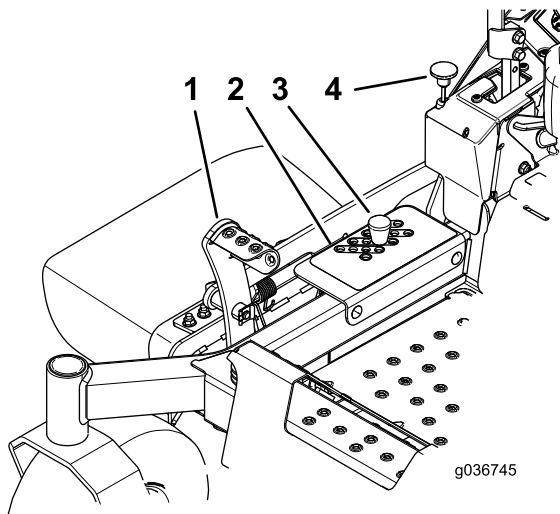

Figure 30

- | | |
|------------------------|------------------------|
| 1. Deck-lift pedal | 3. Height-of-cut pin |
| 2. Height-of-cut holes | 4. Transport lock knob |

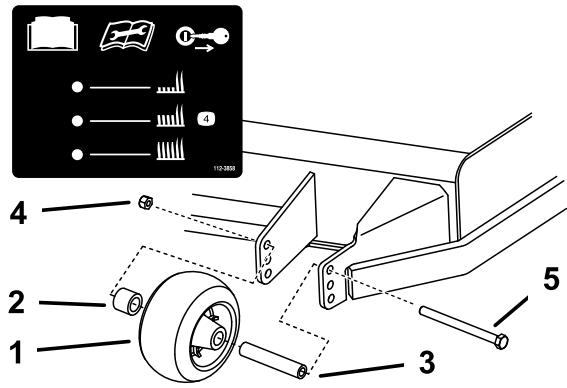

Figure 31

- | | |
|----------------------|---------------|
| 1. Anti-scalp roller | 4. Flange nut |
| 2. Spacer | 5. Bolt |
| 3. Bushing | |

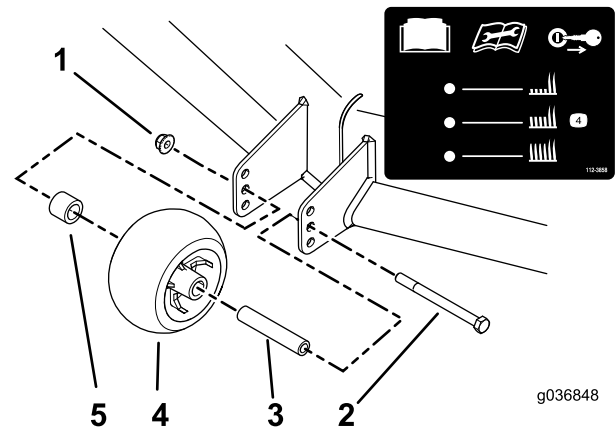

Figure 32

- | | |
|---------------|----------------------|
| 1. Flange nut | 4. Anti-scalp roller |
| 2. Bolt | 5. Bushing |
| 3. Spacer | |

Adjusting the Anti-Scalp Rollers

Whenever you change the height-of-cut, adjust the height of the anti-scalp rollers.

1. Disengage the blade-control switch (PTO), move the motion-control levers to the NEUTRAL-LOCK position, and engage the parking brake.
2. Stop the engine, remove the key, and wait for all moving parts to stop before leaving the operating position.

Stopping the Machine

To stop the machine, move the motion-control levers to neutral and then to the NEUTRAL-LOCK position, disengage the blade-control switch (PTO), and turn the ignition key to the OFF position.

Engage the parking brake when you leave the machine; refer to [Engaging the Parking Brake \(page 20\)](#). Remove the key from the ignition switch.

⚠ CAUTION

Children or bystanders may be injured if they move or attempt to operate the machine while it is unattended.

Always remove the ignition key and engage the parking brake when leaving the machine unattended, even if just for a few minutes.

Using the Side Discharge

The mower has a hinged grass deflector that disperses clippings to the side and down toward the turf.

⚠ DANGER

Without a grass deflector, discharge cover, or a complete grass-catcher assembly mounted in place, you and others are exposed to blade contact and thrown debris. Contact with rotating mower blade(s) and thrown debris will cause injury or death.

- Never remove the grass deflector from the mower because the grass deflector routes material down toward the turf. If the grass deflector is ever damaged, replace it immediately.
- Never put your hands or feet under the mower.
- Never try to clear the discharge area or mower blades unless you move the blade-control switch (PTO) to the OFF position, rotate the ignition key to the OFF position, and remove the key.
- Make sure that the grass deflector is in the down position.

Operating Tips

Using the Fast Throttle Setting

For best mowing and maximum air circulation, operate the engine at the FAST position. Air is required to thoroughly cut grass clippings, so do not set the height-of-cut so low as to totally surround the mower in uncut grass. Always try to have 1 side of the mower free from uncut grass, which allows air to be drawn into the mower.

Cutting a Lawn for the First Time

Cut grass slightly longer than normal to ensure that the cutting height of the mower does not scalp any uneven ground. However, the cutting height used in the past is generally the best one to use. When cutting grass longer than 15 cm (6 inches) tall, you may want to cut the lawn twice to ensure an acceptable quality of cut.

Cutting a Third of the Grass Blade

It is best to cut only about a third of the grass blade. Cutting more than that is not recommended unless grass is sparse, or it is late fall when grass grows more slowly.

Alternating the Mowing Direction

Alternate the mowing direction to keep the grass standing straight. This also helps disperse clippings which enhances decomposition and fertilization.

Mowing at Correct Intervals

Grass grows at different rates at different times of the year. To maintain the same cutting height, mow more often in early spring. As the grass growth rate slows in mid summer, mow less frequently. If you cannot mow for an extended period, first mow at a high cutting height, then mow again 2 days later at a lower height setting.

Using a Slower Cutting Speed

To improve cut quality, use a slower ground speed in certain conditions.

Avoiding Cutting Too Low

When mowing uneven turf, raise the cutting height to avoid scalping the turf.

Stopping the Machine

If you must stop the forward motion of the machine while mowing, a clump of grass clippings may drop onto your lawn. To avoid this, move onto a previously cut area with the blades engaged or you can disengage the mower deck while moving forward.

Keeping the Underside of the Mower Clean

Clean clippings and dirt from the underside of the mower after each use. If grass and dirt build up inside the mower, cutting quality will eventually become unsatisfactory.

Maintaining the Blade(s)

Maintain a sharp blade throughout the cutting season because a sharp blade cuts cleanly without tearing or shredding the grass blades. Tearing and shredding turns grass brown at the edges, which slows growth and increases the chance of disease. Check the mower blades after each use for sharpness, and for any wear or damage. File down any nicks and sharpen the blades as necessary. If a blade is damaged or worn, replace it immediately with a genuine Toro replacement blade.

After Operation

After Operation Safety

General Safety

- Clean grass and debris from the cutting units, mufflers, and engine compartment to help prevent fires. Clean up oil or fuel spills.
- Shut off the fuel before storing or transporting the machine.
- Disengage the drive to the attachment whenever you are transporting or not using the machine.
- Use full-width ramps for loading the machine into a trailer or truck.
- Tie the machine down securely using straps, chains, cable, or ropes. Both front and rear straps should be directed down and outward from the machine.
- Allow the engine to cool before storing the machine in any enclosure.
- Shut off the fuel before storing or transporting the machine.
- Never store the machine or fuel container where there is an open flame, spark, or pilot light, such as on a water heater or on other appliances.

Using the Fuel-Shutoff Valve

The fuel-shutoff valve is located behind the seat.

Close the fuel-shutoff valve for transport, maintenance, and storage.

Ensure that the fuel-shutoff valve is open when starting the engine.

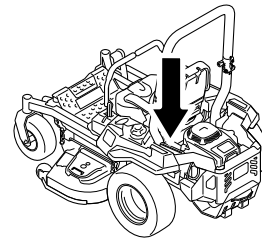

g036849

g036849

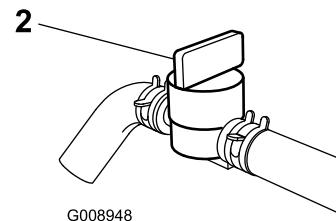
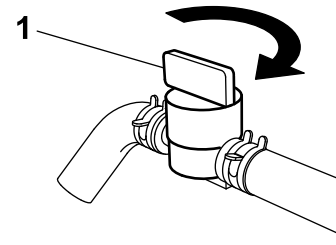

G008948

g008948

Figure 33

1. On position

2. Off position

Using the Drive-Wheel-Release Valves

⚠ WARNING

Hands may become entangled in the rotating drive components below the engine deck, which could result in serious injury.

Shut off the engine, remove the key, and allow all moving parts to stop before accessing the drive-wheel-release valves.

⚠ WARNING

The engine and hydraulic-drive units can become very hot. Touching a hot engine or hydraulic-drive units can cause severe burns.

Allow the engine and hydraulic-drive units to cool completely before accessing the drive-wheel-release valves.

The drive-wheel-release valves are located on the left and right sides underneath the engine deck.

1. Disengage the blade-control switch (PTO), turn the ignition key to off, move the levers to the

NEUTRAL-LOCK position, apply the parking brake, and remove the key.

2. Locate the bypass levers behind the seat, down on the left and right side of the frame.
3. To push the machine, move both bypass knobs rearward and lock them into place (Figure 34).
4. Disengage the parking brake before pushing the machine.

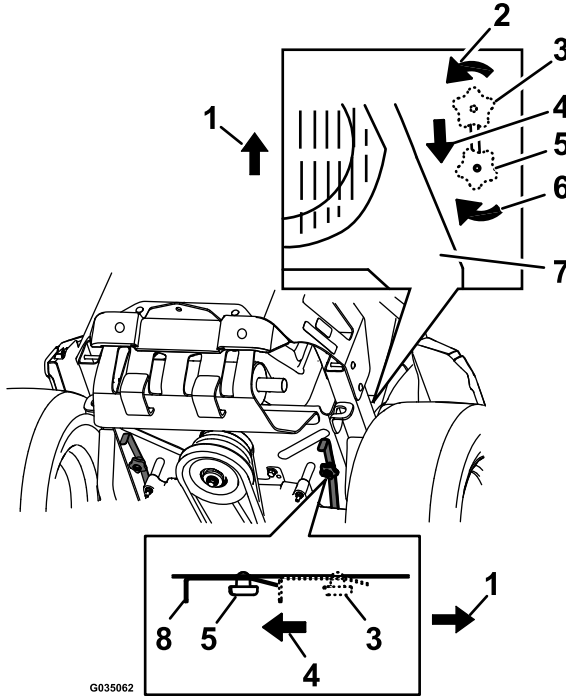

Figure 34

1. Front of the machine
2. Rotate bypass release knob counterclockwise to loosen.
3. Lever position for operating the machine
4. Pull the lever in this direction to push the machine.
5. Lever position for pushing the machine
6. Rotate the bypass-release knob clockwise to tighten.
7. Engine
8. Release lever

5. To run the machine, move the bypass knobs to the FORWARD position and lock them into place (Figure 34).

Transporting the Machine

Use a heavy-duty trailer or truck to transport the machine. Ensure that the trailer or truck has all necessary brakes, lighting, and marking as required by law. Please carefully read all the safety instructions. Knowing this information could help you, your family, pets, or bystanders avoid injury.

⚠ WARNING

Driving on the street or roadway without turn signals, lights, reflective markings, or a slow-moving-vehicle emblem is dangerous and can lead to accidents, causing personal injury.

Do not drive the machine on a public street or roadway.

To transport the machine:

1. If you are using a trailer, connect it to the towing vehicle and connect the safety chains.
2. If applicable, connect the trailer brakes.
3. Load the machine onto the trailer or truck.
4. Shut off the engine, remove the key, set the brake, and close the fuel valve.
5. Use the metal tie-down loops on the machine to securely fasten it to the trailer or truck with straps, chains, cable, or ropes (Figure 35).

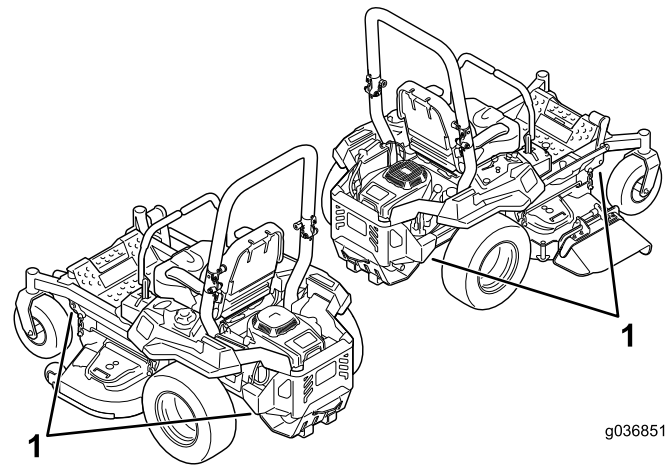

Figure 35

1. Tie-down loops

Loading the Machine

Use extreme caution when loading or unloading machines onto a trailer or a truck. Use a full-width ramp that is wider than the machine for this procedure. Back up the ramp and drive forward down the ramp (Figure 36).

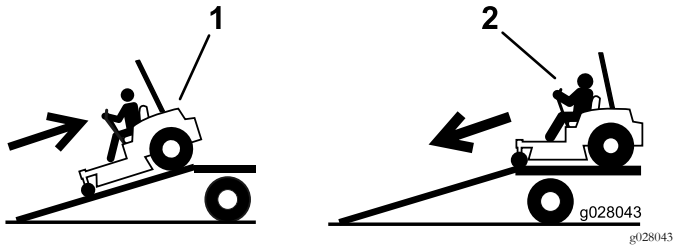

Figure 36

1. Back the machine up the ramp.
2. Drive the machine forward down the ramp.

Important: Do not use narrow individual ramps for each side of the machine.

⚠ WARNING

Loading a machine onto a trailer or truck increases the possibility of tip-over and could cause serious injury or death (Figure 37).

- Use extreme caution when operating a machine on a ramp.
- Use only a full-width ramp; do not use individual ramps for each side of the machine.
- Do not exceed a 15-degree angle between the ramp and the ground or between the ramp and the trailer or truck.
- Ensure that the length of ramp is at least 4 times as long as the height of the trailer or truck bed to the ground. This ensures that the ramp angle does not exceed 15 degrees on flat ground.
- Back up ramps and drive forward down ramps.
- Avoid sudden acceleration or deceleration while driving the machine on a ramp as this could cause a loss of control or a tip-over situation.

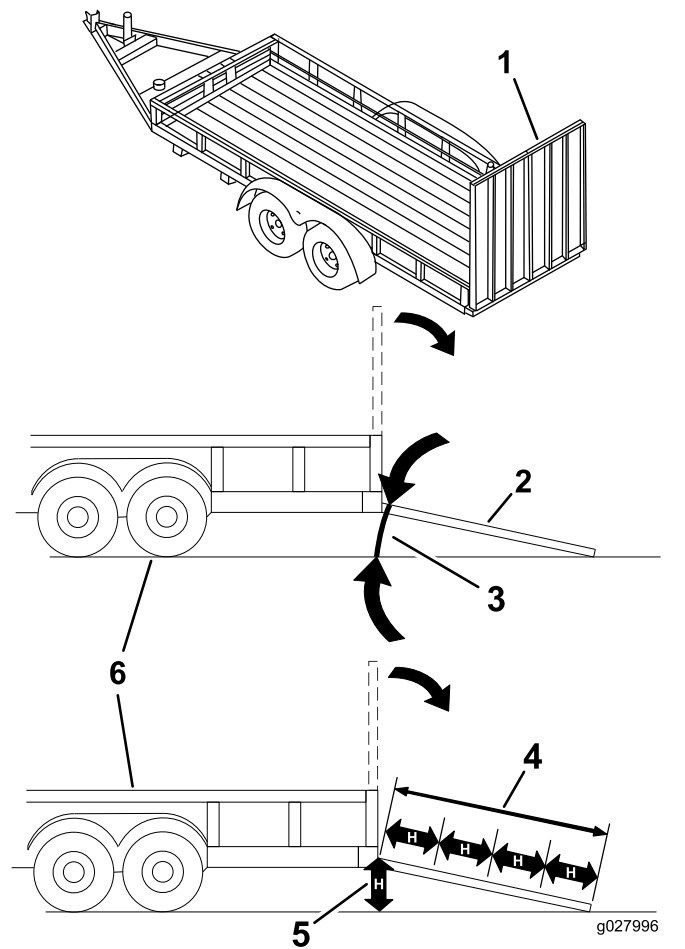

Figure 37

1. Full-width ramp in stowed position
2. Side view of full-width ramp in loading position
3. Not greater than 15 degrees
4. Ramp is at least 4 times as long as the height of the trailer or truck bed to the ground
5. H=height of the trailer or truck bed to the ground
6. Trailer

Maintenance

Recommended Maintenance Schedule(s)

Maintenance Service Interval	Maintenance Procedure
After the first 5 hours	<ul style="list-style-type: none"> • For Toro engines—change the engine oil and filter.
After the first 75 hours	<ul style="list-style-type: none"> • Change the hydraulic-system filters and fluid.
Before each use or daily	<ul style="list-style-type: none"> • Check the safety system. • For Toro engines—check the engine-oil level. • Clean the air-intake screen. • Check the seat belt. • Check the roll bar knobs. • Clean the engine screen and the area around the engine. • Clean around the engine-exhaust system. • Check the hydraulic fluid level in the expansion tank. • Inspect the blades. • Clean the mower deck.
Every 25 hours	<ul style="list-style-type: none"> • Grease the front caster axles. (more often in dirty or dusty conditions). • For Toro engines—clean the air-cleaner foam element (more often in dusty, dirty conditions).
Every 50 hours	<ul style="list-style-type: none"> • Grease the pump-idler pivot. • Check spark arrester (if equipped). • Check the tire pressure. • Inspect the belts for cracks and wear.
Every 100 hours	<ul style="list-style-type: none"> • For Toro engines—replace the air-cleaner foam element (more often in dusty, dirty conditions). • For Toro engines—service the air-cleaner paper element (more often in dusty, dirty conditions). • For Toro engines—change the engine oil and oil filter (more often in dusty, dirty conditions). • For Toro engines—check the spark plug(s).
Every 200 hours	<ul style="list-style-type: none"> • For Toro engines—replace the air-cleaner paper element (more often in dusty, dirty conditions). • For Toro engines—replace the spark plug(s).
Every 250 hours	<ul style="list-style-type: none"> • After the initial change—change the hydraulic-system filters and fluid when using Mobil 1 15W50 fluid (change it more often under severe conditions).
Every 500 hours	<ul style="list-style-type: none"> • Replace the emissions-air intake filter. • Replace the fuel filter (more often in dusty, dirty conditions). • Check the parking brake adjustment. • After the initial change—change the hydraulic-system filters and fluid when using Toro® HYPR-OIL™ 500 oil (change it more often under severe conditions).
Monthly	<ul style="list-style-type: none"> • Check the battery charge.
Yearly or before storage	<ul style="list-style-type: none"> • Paint chipped surfaces. • Check all maintenance procedures listed above before storage.

Important: Refer to your engine operator's manual for additional maintenance procedures.

▲ CAUTION

If you leave the key in the ignition switch, someone could accidentally start the engine and seriously injure you or other bystanders.

Remove the key from the ignition before you do any maintenance.

Pre-Maintenance Procedures

Maintenance and Storage

- Before repairing the machine do the following:
 - Disengage the drives.
 - Engage the parking brake.
 - Shut off the engine and remove the key.
 - Disconnect the spark-plug wire.
- Park the machine on a level surface.
- Clean grass and debris from the cutting unit, drives, mufflers, and engine to help prevent fires.
- Clean up oil or fuel spills.
- Let the engine cool before storing the machine.
- Do not store the machine or fuel near flames or drain the fuel indoors.
- Do not allow untrained personnel to service the machine.
- Use jack stands to support the machine and/or components when required.
- Carefully release pressure from components with stored energy.
- Disconnect the battery or remove the spark-plug wire before making any repairs. Disconnect the negative terminal first and the positive terminal last. Connect the positive terminal first and negative last.
- Use care when checking the blades. Wrap the blade(s) or wear thickly padded gloves, and use caution when servicing them. Only replace blades; do not straighten or weld them.
- Keep your hands and feet away from moving parts. If possible, do not make adjustments with the engine running.
- Keep all parts in good working condition and all hardware tightened, especially the blade-attachment bolts. Replace all worn or damaged decals.
- Never interfere with the intended function of a safety device or reduce the protection provided by a safety device. Check their proper operation regularly.
- To ensure optimum performance and continued safety certification of the machine, use only genuine Toro replacement parts and accessories. Replacement parts and accessories made by other manufacturers could be dangerous, and such use could void the product warranty.
- Check the parking brake operation frequently. Adjust and service as required.

Releasing the Mower-Deck Curtain

Loosen the top bolt of the curtain to release the mower-deck curtain and access the top of the mower deck (Figure 38). Tighten the bolt after maintenance to install the curtain.

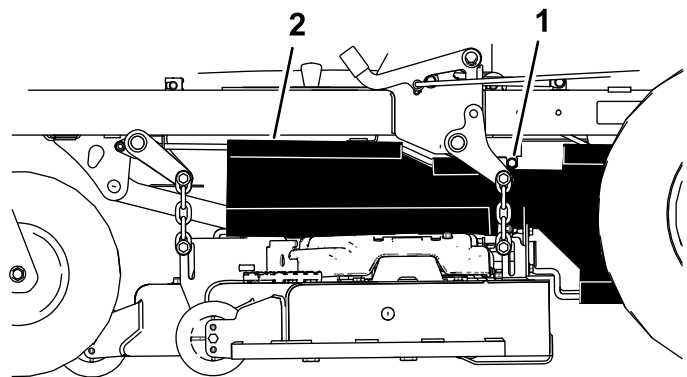

Figure 38

1. Bolt
2. Curtain

Removing the Sheet-Metal Guard

1. Remove the floor pan and the bolts attached to it (Figure 39).

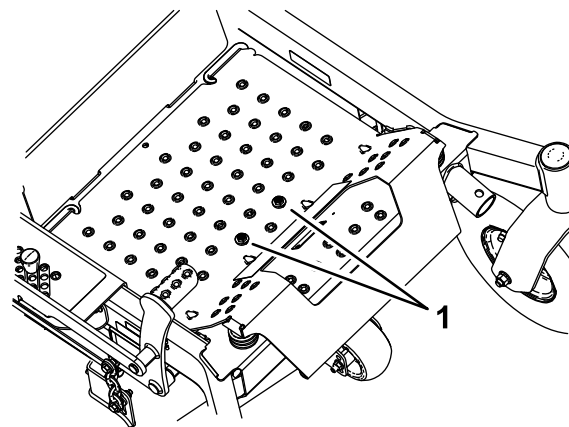
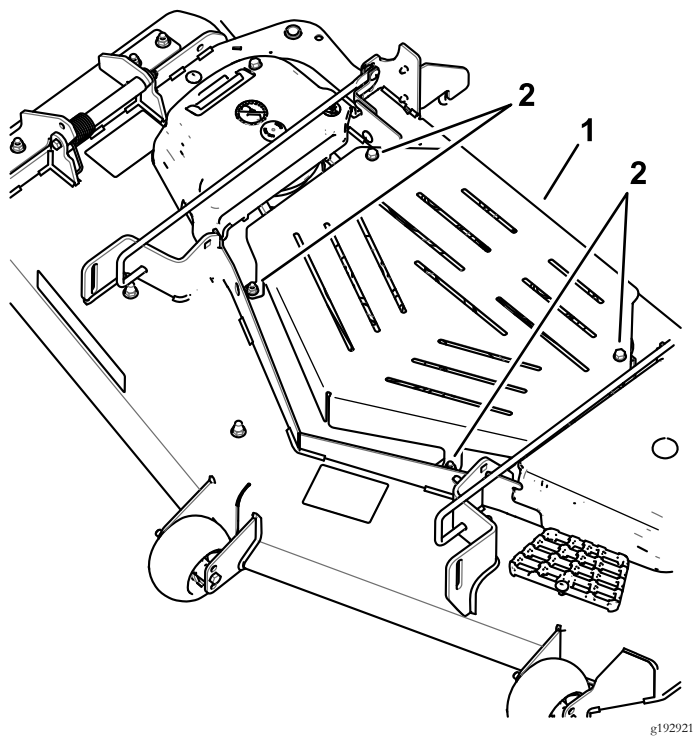

Figure 39

1. Bolts
2. Loosen the 2 front bolts and remove the sheet-metal guard to access the mower belts and spindles (Figure 40). Install the sheet-metal guard and tighten the bolts after maintenance.



g192921

Figure 40

1. Sheet-metal guard 2. Bolt
-

Lubrication

Grease more frequently when operating conditions are extremely dusty or sandy.

Grease Type: No. 2 general-purpose lithium-based or molybdenum-based grease

1. Disengage the blade-control switch (PTO), move the motion-control levers to the NEUTRAL-LOCK position, and engage the parking brake.
2. Shut off the engine, remove the key, and wait for all moving parts to stop before leaving the operating position.
3. Clean the grease fittings with a rag.

Note: Make sure that you scrape any paint off the front of the fitting(s).

4. Connect a grease gun to the fitting.
5. Pump grease into the fittings until grease begins to ooze out of the bearings.
6. Wipe up any excess grease.

Greasing the Machine

Service Interval: Every 25 hours—Grease the front caster axles. (more often in dirty or dusty conditions).

Every 50 hours—Grease the pump-idler pivot.

1. Disengage the blade-control switch (PTO), move the motion-control levers to the NEUTRAL-LOCK position, and engage the parking brake.
2. Shut off the engine, remove the key, and wait for all moving parts to stop before leaving the operating position.
3. Grease the pump idler-pulley pivot with 1 or 2 pumps of grease (Figure 41).
4. Grease the front caster axles (Figure 41).

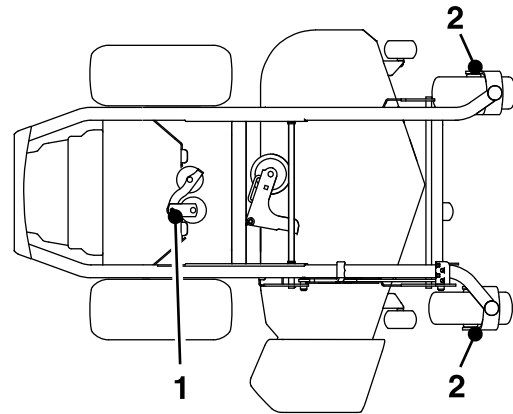

Figure 41

1. Pump-idler pivot
2. Caster axle

g188563

Engine Maintenance

⚠ WARNING

Contact with hot surfaces may cause personal injury.

Keep hands, feet, face, clothing and other body parts away the muffler and other hot surfaces.

Engine Safety

Shut off the engine before checking the oil or adding oil to the crankcase.

Servicing the Engine

Servicing the Air Cleaner

Service Interval: Every 25 hours/Monthly (whichever comes first)—For Toro engines—clean the air-cleaner foam element (more often in dusty, dirty conditions).

Every 100 hours/Yearly (whichever comes first)—For Toro engines—replace the air-cleaner foam element (more often in dusty, dirty conditions).

Every 100 hours/Yearly (whichever comes first)—For Toro engines—service the air-cleaner paper element (more often in dusty, dirty conditions).

Every 200 hours/Every 2 years (whichever comes first)—For Toro engines—replace the air-cleaner paper element (more often in dusty, dirty conditions).

Removing the Elements

1. Park the machine on a level surface and disengage the blade-control switch (PTO).
2. Engage the parking brake, shut off the engine, remove the key, and wait for all moving parts to stop before leaving the operating position.
3. Clean around the air-cleaner cover to prevent dirt from getting into the engine and causing damage.
4. Lift the cover and rotate the air-cleaner assembly out of the engine (Figure 42).

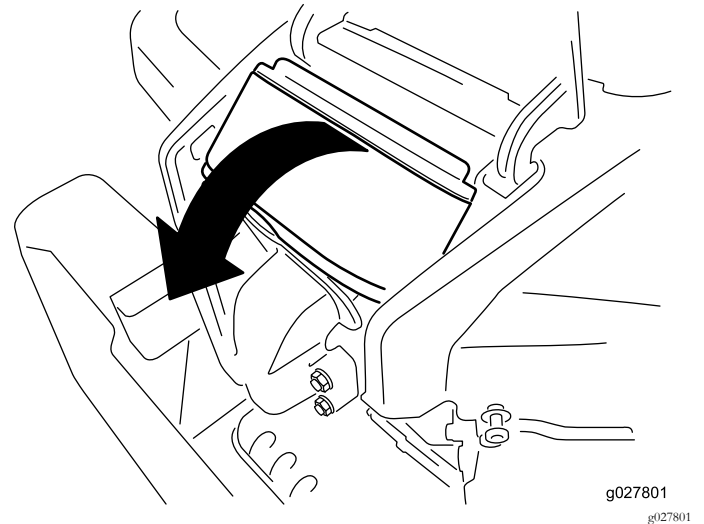
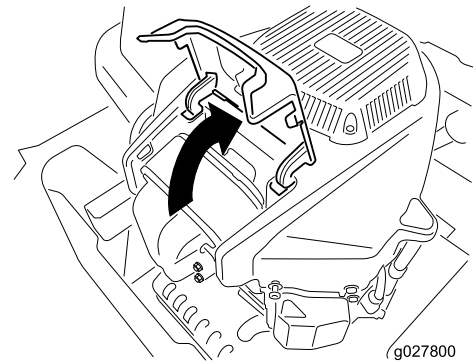

Figure 42

5. Remove the foam element from the paper element (Figure 43).

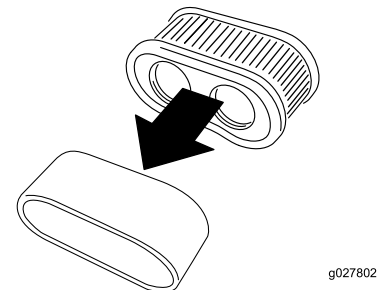

Figure 43

Servicing the Foam Element

Wash the foam element with water and replace it if it is damaged.

Servicing the Paper Element

1. Lightly tap the element on a flat surface to remove dust and dirt.
2. Inspect the element for tears, an oily film, and damage to the seal.

Important: Do not clean the paper element with pressurized air or liquids, such as solvent, gas, or kerosene. Replace the paper element if it is damaged or cannot be cleaned thoroughly.

Servicing the Engine Oil

Oil Type: Detergent oil (API service SF, SG, SH, SJ, or SL)

Crankcase Capacity: 2.4 L (80 oz) with filter

Viscosity: See the table below.

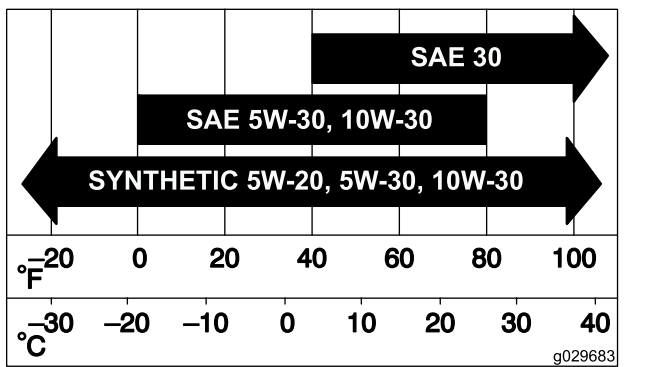

Figure 44

Checking the Engine-Oil Level

Service Interval: Before each use or daily—For Toro engines—check the engine-oil level.

Note: Check the oil when the engine is cold.

⚠ WARNING

Contact with hot surfaces may cause personal injury.

Keep hands, feet, face, clothing, and other body parts away the muffler and other hot surfaces.

Important: Do not overfill the crankcase with oil, because damage to the engine may result. Do not run engine with oil below the Low mark, because the engine may be damaged.

1. Park the machine on a level surface, disengage the blade-control switch, shut off the engine, engage the parking brake, and remove the key.
2. Make sure that the engine is shut off, level, and is cool so that the oil has had time to drain into the sump.

3. To keep dirt, grass clippings, etc., out of the engine, clean the area around the oil-fill cap and dipstick before removing it (Figure 45).

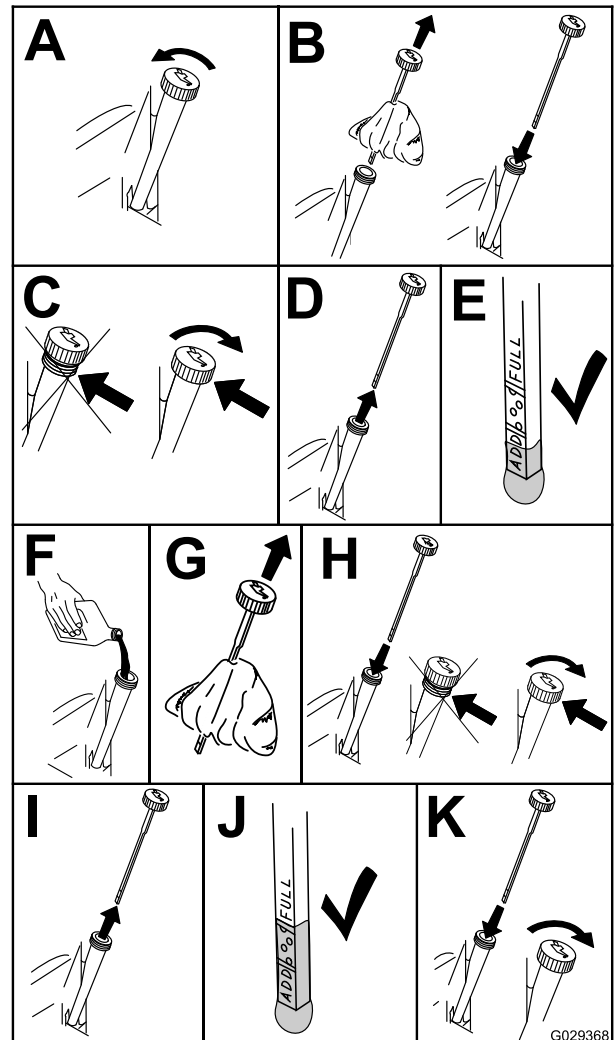

Figure 45

Changing the Engine Oil and Oil Filter

Service Interval: After the first 5 hours/After the first month (whichever comes first)—For Toro engines—change the engine oil and filter.

Every 100 hours/Yearly (whichever comes first)—For Toro engines—change the engine oil and oil filter (more often in dusty, dirty conditions).

Note: Dispose of the used oil at a recycling center.

1. Park the machine on a level surface to ensure the oil drains completely.
2. Disengage the PTO and engage the parking brake.
3. Shut off the engine, remove the key, and wait for all moving parts to stop before leaving the operating position.

4. Drain the engine oil (Figure 46).

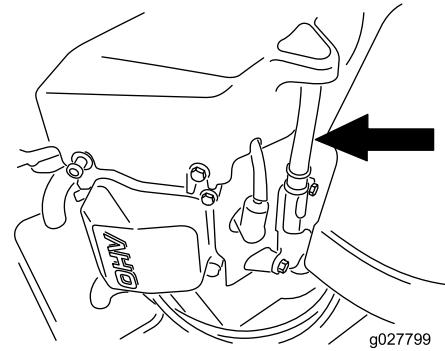

g027799

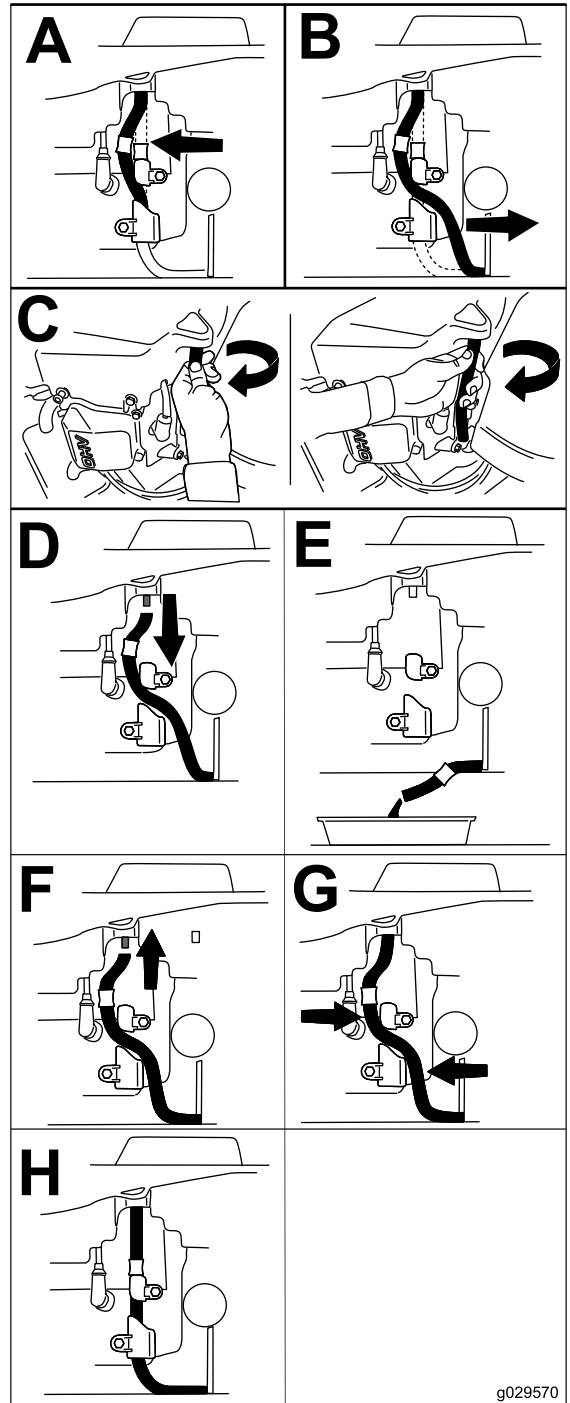

g029570

Figure 46

g029570

5. Change the engine-oil filter (Figure 47).

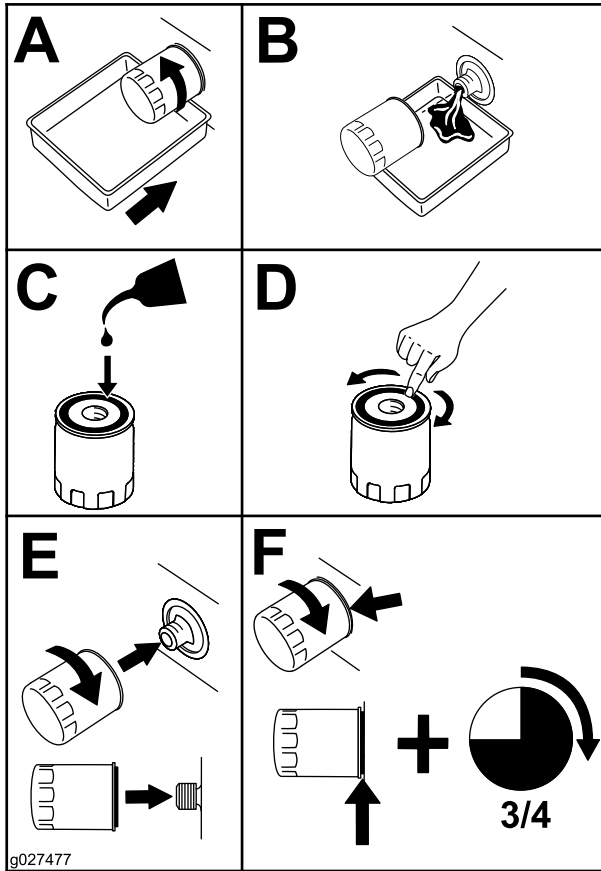

Figure 47

Note: Ensure that the oil-filter gasket touches the engine and then turn the filter an extra 3/4 turn.

6. Slowly pour approximately 80% of the specified oil into the filler tube and slowly add the additional oil to bring it to the **Full** mark (Figure 48).

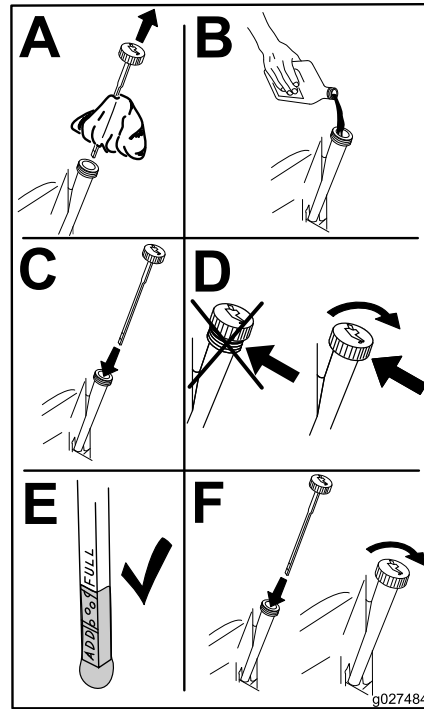

Figure 48

Servicing the Spark Plug

Service Interval: Every 100 hours/Yearly (whichever comes first)—For Toro engines—check the spark plug(s).

Every 200 hours/Every 2 years (whichever comes first)—For Toro engines—replace the spark plug(s).

Make sure that the air gap between the center and side electrodes is correct before installing the spark plug. Use a spark-plug wrench to remove and install the spark plug(s) and a gapping tool/feeler gauge to check and adjust the air gap. Install a new spark plug(s) if necessary.

Type: Champion RN9YC or NGK BPR6ES

Air gap: 0.76 mm (0.03 inch)

Removing the Spark Plug

1. Disengage the PTO and engage the parking brake.
2. Shut off the engine, remove the key, and wait for all moving parts to stop before leaving the operating position.

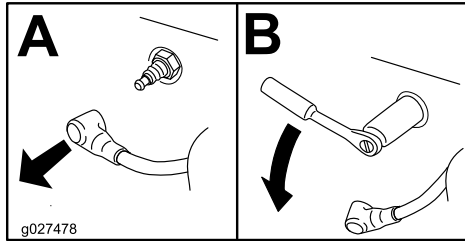

Figure 49

g027478

Note: Due to the deep recess around the spark plug, blowing out the cavity with compressed air is usually the most effective method for cleaning. The spark plug is most accessible when the blower housing is removed for cleaning.

Checking the Spark Plug

Important: Do not clean the spark plug(s). Always replace the spark plug(s) when it has: a black coating, worn electrodes, an oily film, or cracks.

If you see light brown or gray on the insulator, the engine is operating properly. A black coating on the insulator usually means the air cleaner is dirty.

Set the gap to 0.76 mm (0.030 inch).

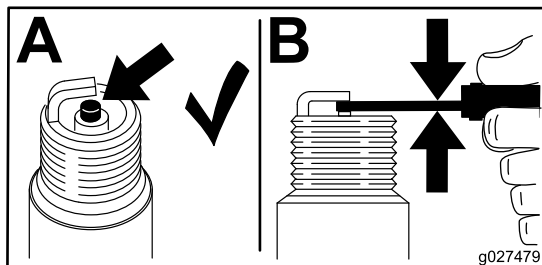

Figure 50

g027479

Installing the Spark Plug

Tighten the spark plug(s) to 25 to 30 N·m (19 to 22 ft-lb).

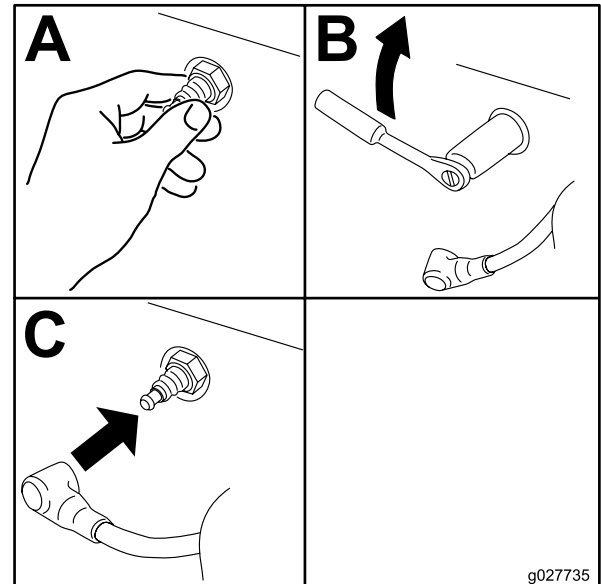

Figure 51

g027735

Cleaning the Cooling System

Clean the air-intake screen from grass and debris before each use.

1. Disengage the blade-control switch and engage the parking brake.
2. Shut off the engine, remove the key, and wait for all moving parts to stop before leaving the operating position.
3. Remove the air filter from the engine.
4. Remove the engine shroud.
5. To prevent debris entering the air intake, install the air filter to the filter base.
6. Clean debris and grass from the parts.
7. Remove the air filter and install the engine shroud.
8. Install the air filter.

Checking the Spark Arrester

For a Model with a Spark Arrester

Service Interval: Every 50 hours

⚠ WARNING

Hot exhaust system components may ignite gasoline vapors even after you shut off the engine. Hot particles exhausted during engine operation may ignite flammable materials. Fire may result in personal injury or property damage.

Do not refuel or run the engine unless a spark arrester is installed.

1. Shut off the engine, wait for all moving parts to stop, and remove the key. Engage the parking brake.
2. Wait for the muffler to cool.
3. If there are any breaks in the screen or welds, replace the arrester.
4. If the screen is plugged, remove the arrester and shake the loose particles out of the arrester and clean the screen with a wire brush (soak it in solvent if necessary). Install the arrester on the exhaust outlet.

Replacing the Emissions-Air Intake Filter

Service Interval: Every 500 hours

1. Shut off the engine, wait for all moving parts to stop, and remove the key. Engage the parking brake.
2. Remove the filter from the vent hose.
3. Insert a new filter into the end of the vent hose.

Fuel System Maintenance

Replacing the Fuel Filter

Service Interval: Every 500 hours/Yearly (whichever comes first) (more often in dusty, dirty conditions).

Important: Install the fuel line hoses and secure with plastic ties the same as they were originally installed at the factory to keep the fuel line away from components that can cause fuel line damage.

The fuel filter is located near the engine on the left front of the engine.

1. Disengage the blade-control switch (PTO), move the motion-control levers to the NEUTRAL-LOCK position, and engage the parking brake.
2. Shut off the engine, remove the key, and wait for all moving parts to stop before leaving the operating position.
3. Allow the machine to cool down.
4. Close the fuel-shutoff valve behind the seat (Figure 33).

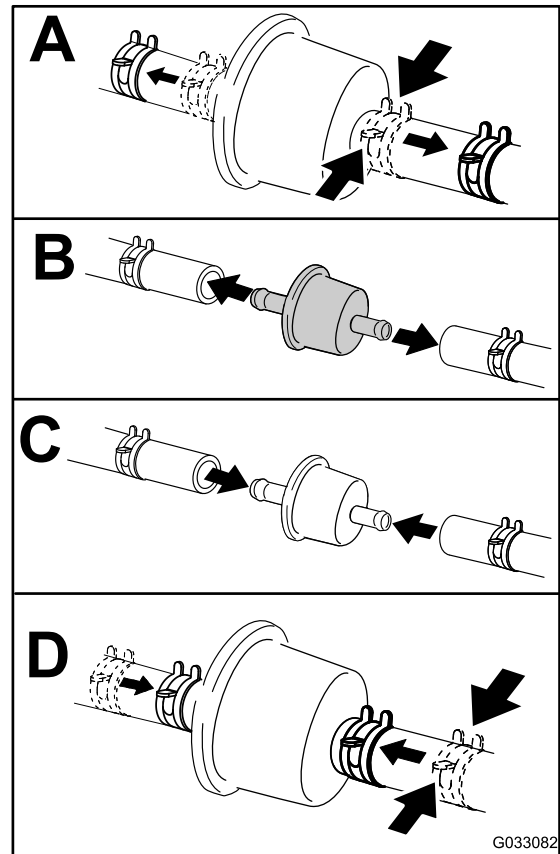

Figure 52

g033082

5. Open the fuel-shutoff valve.

Servicing the Fuel Tank

Do not attempt to drain the fuel tank. Ensure that an Authorized Service Dealer drains the fuel tank and services any components of the fuel system.

Electrical System Maintenance

Electrical System Safety

- Disconnect the battery before repairing the machine. Disconnect the negative terminal first and the positive last. Connect the positive terminal first and the negative last.
- Charge the battery in an open, well-ventilated area, away from sparks and flames. Unplug the charger before connecting or disconnecting the battery. Wear protective clothing and use insulated tools.

WARNING

CALIFORNIA Proposition 65 Warning

Battery posts, terminals, and related accessories contain lead and lead compounds, chemicals known to the State of California to cause cancer and reproductive harm.
Wash hands after handling.

Servicing the Battery

Service Interval: Monthly

⚠ DANGER

Battery electrolyte contains sulfuric acid, which is a deadly poison and causes severe burns.

Do not drink electrolyte and avoid contact with skin, eyes, or clothing. Wear safety glasses to shield your eyes and wear rubber gloves to protect your hands.

Removing the Battery

⚠ WARNING

Battery terminals or metal tools could short against metal machine components, causing sparks. Sparks can cause the battery gasses to explode, resulting in personal injury.

- When removing or installing the battery, do not allow the battery terminals to touch any metal parts of the machine.
- Do not allow metal tools to short between the battery terminals and metal parts of the machine.

⚠ WARNING

Incorrect battery cable routing could damage the machine and cables, causing sparks. Sparks can cause the battery gasses to explode, resulting in personal injury.

- Always disconnect the negative (black) battery cable before disconnecting the positive (red) cable.
 - Always connect the positive (red) battery cable before connecting the negative (black) cable.
1. Disengage the blade-control switch (PTO), move the motion-control levers to the NEUTRAL-LOCK position, and engage the parking brake.
 2. Shut off the engine, remove the key, and wait for all moving parts to stop before leaving the operating position.
 3. Disconnect the negative battery cable (black) from the negative (-) battery terminal (Figure 53).
 4. Slide the red terminal boot off the positive (red) battery terminal, and remove the positive (+) battery cable (Figure 53).
 5. Remove the rubber strap (Figure 53).
 6. Remove the battery.

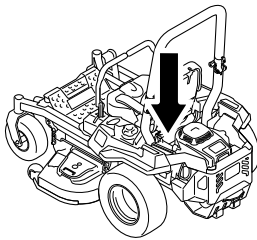

g036853

g036853

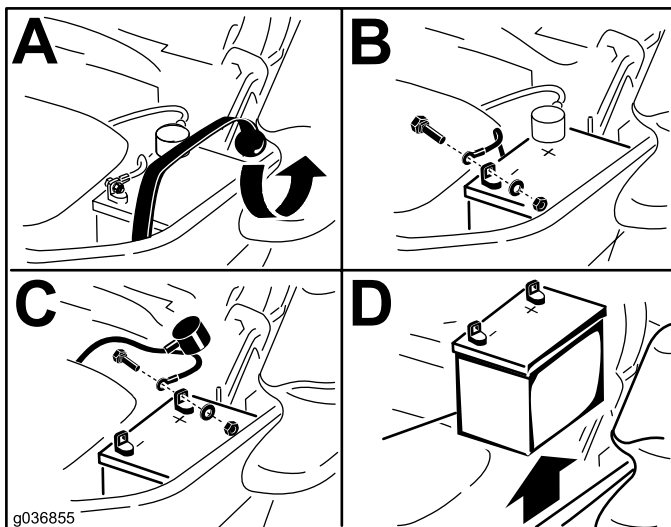

g036855

g036855

Figure 53

Installing the Battery

1. Position the battery in the tray with the terminal posts opposite from the hydraulic tank (Figure 53).
2. Install the positive (red) battery cable to the positive (+) battery terminal.
3. Install the negative (black) battery cable and ground wire to the negative (-) battery terminal.
4. Secure the cables with 2 bolts, 2 washers, and 2 locknuts (Figure 53).
5. Slide the red terminal boot onto the positive (+) battery terminal.
6. Secure the battery with the rubber strap (Figure 53).

Charging the Battery

⚠ WARNING

Charging the battery produces gasses that can explode.

Never smoke near the battery and keep sparks and flames away from the battery.

Important: Always keep the battery fully charged (1.265 specific gravity). This is especially important to prevent battery damage when the temperature is below 0°C (32°F).

1. Charge battery for 10 to 15 minutes at 25 to 30 A or for 30 minutes at 10 A.
2. When the battery is fully charged, unplug the charger from the electrical outlet, then disconnect the charger leads from the battery posts (Figure 54).
3. Install the battery in the machine and connect the battery cables; refer to [Installing the Battery](#) (page 42).

Note: Do not run the machine with the battery disconnected; electrical damage may occur.

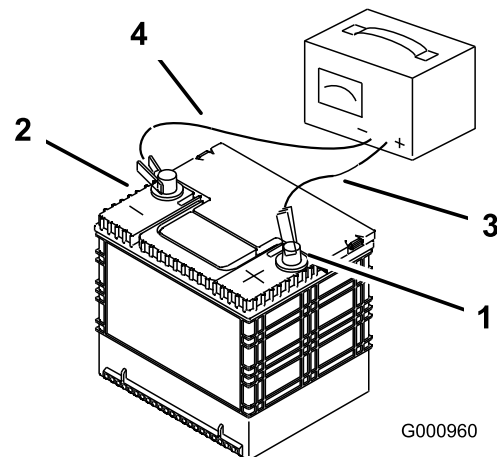

G000960

g000960

Figure 54

1. Positive battery post
2. Negative battery post
3. Red (+) charger lead
4. Black (-) charger lead

Servicing the Fuses

The electrical system is protected by fuses. It requires no maintenance, however, if a fuse blows check the component and circuit for a malfunction or short.

The fuses are located on the right console next to the seat (Figure 55).

1. To replace the fuses, pull out the fuse to remove it.
2. Install a new fuse (Figure 55).

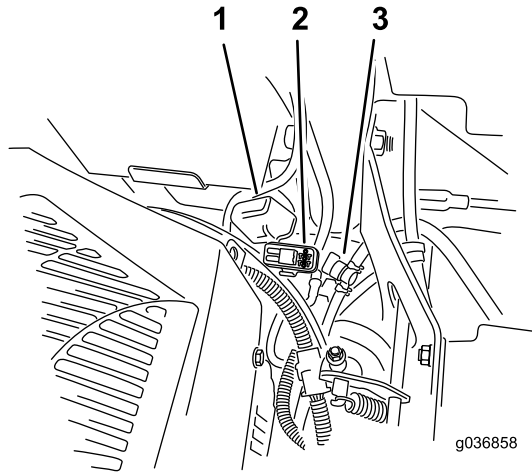

Figure 55

1. Fuse cover
2. Fuse holder
3. Fuel-shutoff valve

Drive System Maintenance

Checking the Seat Belt

Service Interval: Before each use or daily

Inspect the seat belt for wear, cuts, and proper operation of the retractor and buckle. Replace the seat belt if it is damaged.

Checking the Roll-Bar Knobs

Service Interval: Before each use or daily

⚠ WARNING

To avoid injury or death from rollover, keep the roll bar in the fully raised, locked position and use the seat belt.

Ensure that the seat is secured to the machine.

- Check that both the mounting hardware and the knobs are in good working condition.
- Make sure that the knobs are fully engaged with the roll bar in the raised position.

Note: The upper hoop of the roll bar may need to be pushed forward or pulled rearward to fully engage both knobs (Figure 56 and Figure 57).

Adjusting the Tracking

1. Disengage the blade-control switch (PTO).
2. Drive to an open, flat area and move the motion-control levers to the NEUTRAL-LOCK position.
3. Move the throttle midway between the FAST and SLOW positions.
4. Move both motion-control levers forward until they both hit the stops in the T-slot.
5. Check which way the machine tracks.
6. If the machine tracks to the right, insert a 3/16 inch hex wrench through the access hole in the right front cover panel and rotate the tracking screw clockwise or counterclockwise to adjust the travel of the lever (Figure 58).
7. If the machine tracks to the left, insert a 3/16 inch hex wrench through the access hole in the right front cover panel and rotate the tracking screw clockwise or counterclockwise to adjust the travel of the lever (Figure 58).
8. Drive the machine and check the full forward tracking.
9. Repeat the adjustment until the desired tracking is obtained.

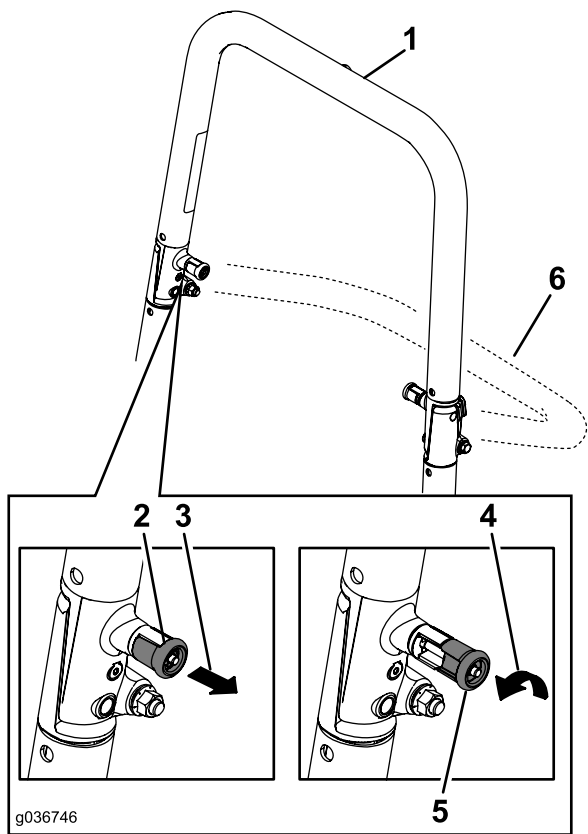

Figure 56

1. Roll bar in the upright position
2. Roll-bar knob in the latched position
3. Pull the roll-bar knob out and rotate it 90 degrees.
4. Rotate the roll-bar knob 90 degrees.
5. Roll-bar knob in the unlatched position
6. Roll bar in the folded position

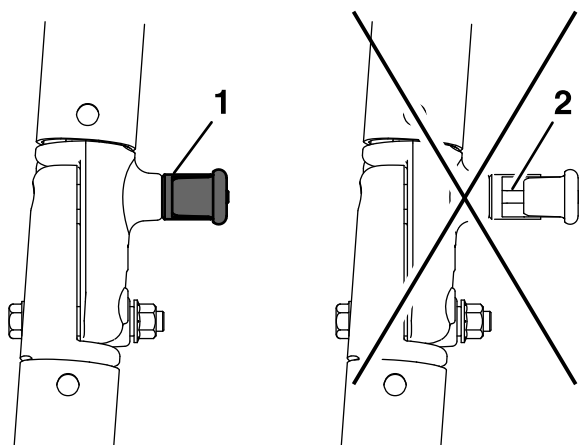

Figure 57

1. Engaged
2. Partially engaged—do not operate with the roll bar in this position.

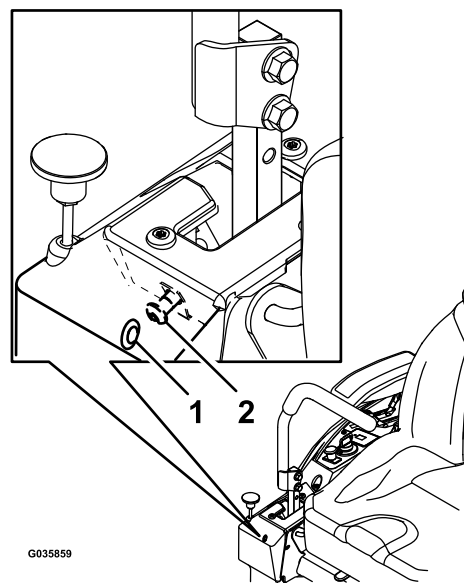

Figure 58

Right control lever shown

1. Access hole on front cover
2. Tracking screw panel

Checking the Tire Pressure

Service Interval: Every 50 hours/Monthly (whichever comes first)

Maintain the air pressure in the front and rear tires at 90 kPa (13 psi). Uneven tire pressure can cause uneven cut. Check the tires when they are cold to get the most accurate pressure reading.

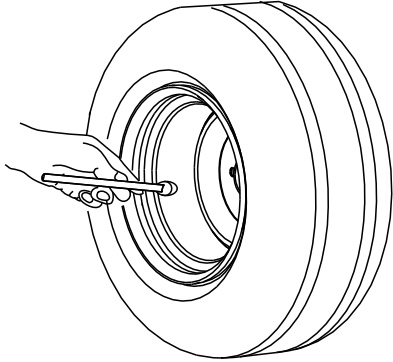

G001055

Figure 59

g001055

Cooling System Maintenance

Cleaning the Engine Screen

Service Interval: Before each use or daily

Before each use or daily

Before each use remove any buildup of grass, dirt, or other debris from the engine screen, engine exhaust, and the area around the engine. This helps ensure adequate cooling and correct engine speed and reduces the possibility of overheating and mechanical damage to the engine.

Checking the Wheel Lug Nuts

Check and torque the wheel lug nuts to 122 to 136 N·m (90 to 100 ft-lb).

Brake Maintenance

Adjusting the Parking Brake

Service Interval: Every 500 hours

Note: Make sure to follow this procedure when a brake component has been removed or replaced.

1. Drive the machine onto a level surface.
2. Disengage the blade-control switch (PTO), move the motion-control levers to the NEUTRAL-LOCK position, and engage the parking brake.
3. Shut off the engine, remove the key, and wait for all moving parts to stop before leaving the operating position.
4. Setup the machine to be pushed by hand. Refer to [Using the Drive-Wheel-Release Valves](#) (page 28).
5. Raise the back of the machine up and support the machine with jack stands.

⚠ CAUTION

Raising the machine for service or maintenance relying solely on mechanical or hydraulic jacks could be dangerous. The mechanical or hydraulic jacks may not be enough support or may malfunction allowing the machine to fall, which could cause injury.

Do not rely solely on mechanical or hydraulic jacks for support. Use adequate jack stands or equivalent support.

6. Engage and disengage the parking brake and check each drive tire to ensure that each brake engages and disengages.
7. If an adjustment is necessary, disengage the parking brake. Remove the cotter pin from the brake linkage shaft ([Figure 60](#)).

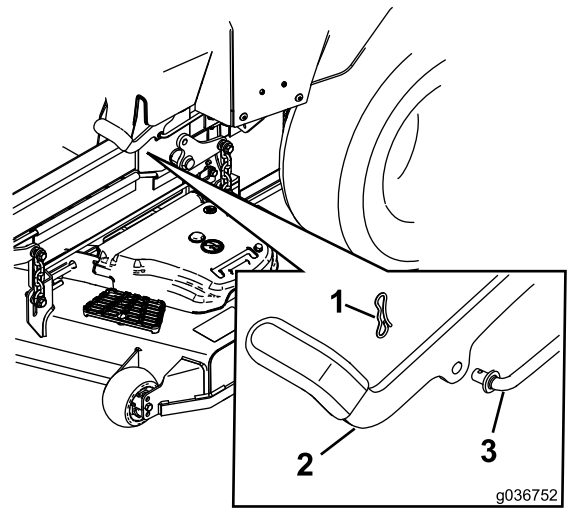

Figure 60

1. Cotter pin
2. Parking brake
3. Brake linkage shaft

8. Check both spring lengths as shown in [Figure 61](#). If an adjustment is necessary, turn the top nut clockwise to shorten the spring and counterclockwise to lengthen it.

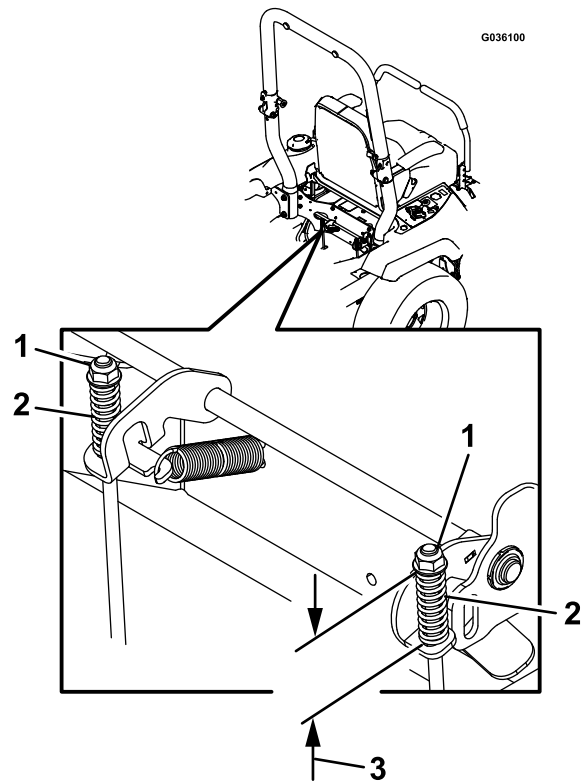

Figure 61

1. Top nut
2. Spring
3. 44 mm (1-3/4 inches)

9. Push the parking brake lever all the way forward and down.

10. Rotate the brake-linkage shaft until the end aligns with the hole in the lever.
 - Shorten the linkage by turning it clockwise.
 - Lengthen the linkage by turning it counterclockwise.
11. Insert the brake-linkage shaft into the parking-brake hole and secure with the cotter pin. Repeat step 6 and adjust if necessary.
12. When adjustment is complete, remove the jack stands or equivalent support and lower the machine.
13. Place the machine into the OPERATING position. Refer to [Using the Drive-Wheel-Release Valves \(page 28\)](#).

Belt Maintenance

Inspecting the Belts

Service Interval: Every 50 hours

Replace the belt if it is worn. The signs of a worn belt include squealing while the belt is rotating; the blades slipping while cutting grass; and frayed edges, burn marks, and cracks on the belt.

Replacing the Mower Belt for Side Discharge Mower Decks

1. Disengage the blade-control switch (PTO), move the motion-control levers to the NEUTRAL-LOCK position, and engage the parking brake.
2. Shut off the engine, remove the key, and wait for all moving parts to stop before leaving the operating position.
3. Lower the mower to the 76 mm (3 inch) height-of-cut.
4. Loosen the bolt on each belt cover.
5. Loosen the bottom bolt holding the mower-deck curtain to the mower deck; refer to [Releasing the Mower-Deck Curtain \(page 32\)](#).
6. Remove the sheet-metal guard; refer to [Removing the Sheet-Metal Guard \(page 32\)](#).
7. Remove the belt covers and the bolts attached to them ([Figure 62](#)).

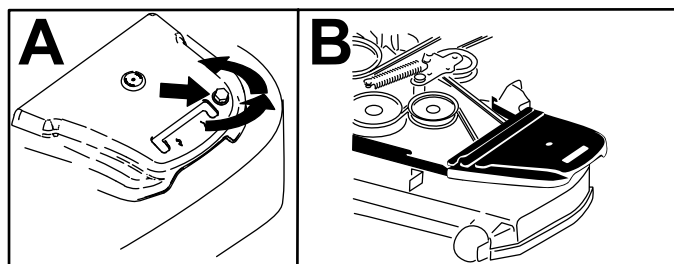

Figure 62

g193173

8. Remove the spring tension from the spring-loaded idler pulley. Refer to [Figure 64](#).

Note: Use the spring removal tool (Toro Part No. 92-5771) to remove the spring from the mower-deck post ([Figure 64](#)).
9. Remove the belt from the mower-deck pulleys and the clutch pulley.
10. Install the new belt around the mower pulleys and the clutch pulley under the engine ([Figure 63](#)).

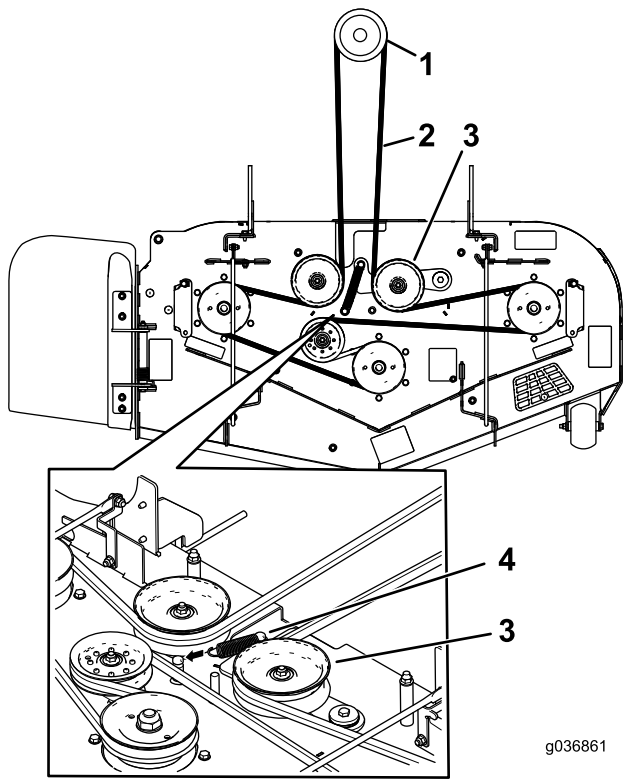

Figure 63

g036861

g036861

- | | |
|------------------|-------------------------------|
| 1. Clutch pulley | 3. Spring-loaded idler pulley |
| 2. Mower belt | 4. Spring |

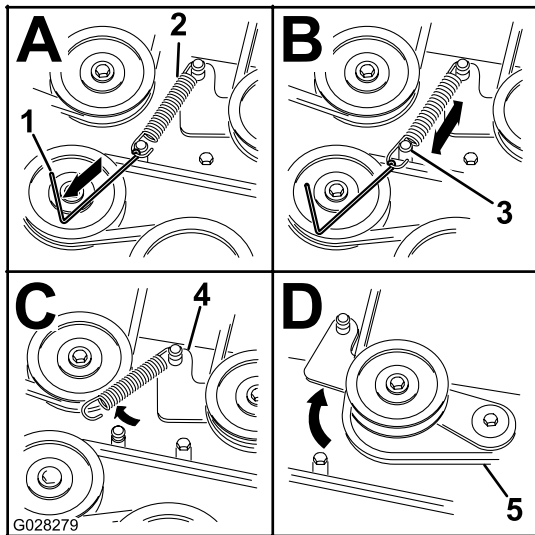

Figure 64

G028279

g028279

- | | |
|--|---------------|
| 1. Spring-removal tool (Toro Part No. 92-5771) | 4. Idler arm |
| 2. Idler spring | 5. Mower belt |
| 3. Mower-deck post | |

11. Install the idler spring (Figure 63).

Note: Make sure to seat the spring ends in the anchor grooves.

12. Install the belt covers and the bolts attached to them (Figure 65).

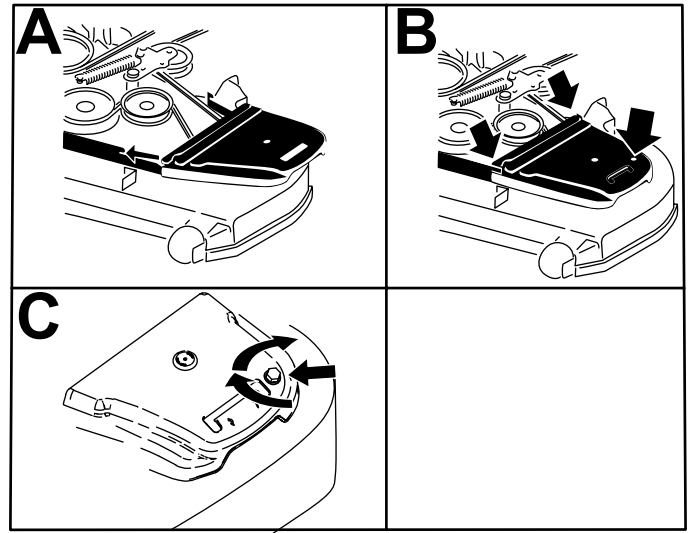

Figure 65

g193175

13. Loosen the bottom bolt holding the mower-deck curtain to the mower deck; refer to [Releasing the Mower-Deck Curtain](#) (page 32).
14. Remove the sheet-metal guard; refer to [Removing the Sheet-Metal Guard](#) (page 32).

Replacing the Hydraulic-Pump-Drive Belt

1. Disengage the blade-control switch (PTO) and engage the parking brake.
2. Shut off the engine, remove the key, and wait for all moving parts to stop before leaving the operating position.
3. Remove the mower belt; refer to [Replacing the Mower Belt for Side Discharge Mower Decks](#) (page 47).
4. Raise the machine and support it with jack stands (Figure 67).
5. Remove the clutch stop (Figure 66).

Controls System Maintenance

Adjusting the Control-Handle Position

1. Disengage the blade-control switch (PTO), move the motion-control levers to the NEUTRAL-LOCK position, and engage the parking brake.
2. Shut off the engine, remove the key, and wait for all moving parts to stop before leaving the operating position.

Adjusting the height:

You can adjust the motion control levers higher or lower for maximum comfort.

- A. Remove the hardware holding the control lever to the control-arm shaft.

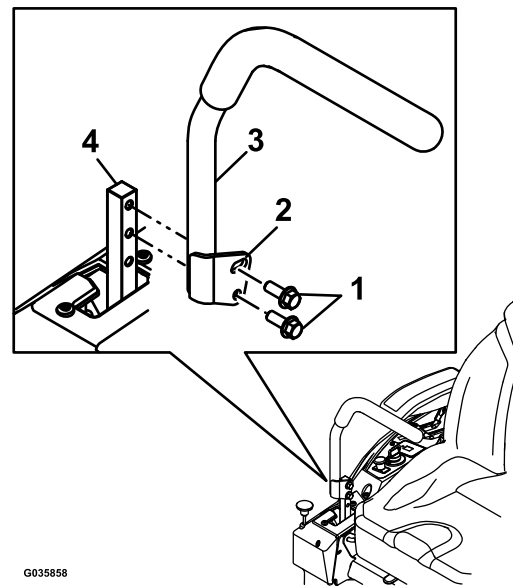

Figure 68

- | | |
|-----------------|----------------------|
| 1. Bolts | 3. Control lever |
| 2. Slotted hole | 4. Control-arm shaft |

- B. Move the control lever to the next set of holes. Secure the lever with the hardware.
- C. Repeat the adjustment for the opposite control lever.

Adjusting the Tilt

- A. Loosen the upper bolt holding the control lever to the control arm shaft.
- B. Loosen the lower bolt just enough to pivot the control lever fore or aft. Tighten both bolts to secure the control in the new position.
- C. Repeat the adjustment for the opposite control lever.

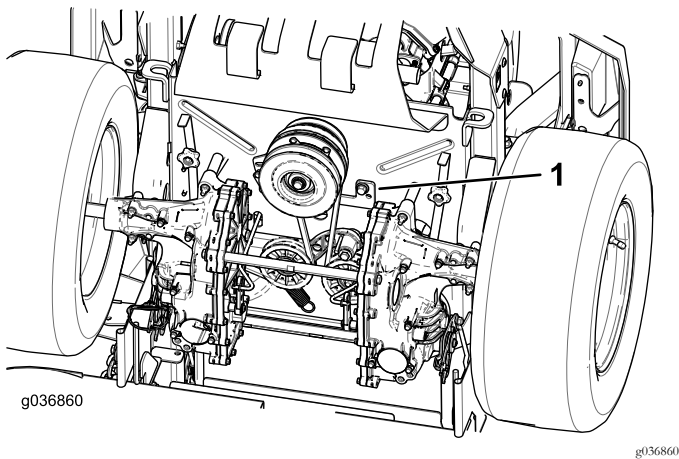

Figure 66

1. Clutch stop

6. Remove the idler spring from the post (Figure 67).
7. Remove the existing belt from the hydraulic-pump-drive pulleys and the engine pulley.
8. Install the new belt around the engine pulley and the 2 hydraulic-pump pulleys (Figure 67).

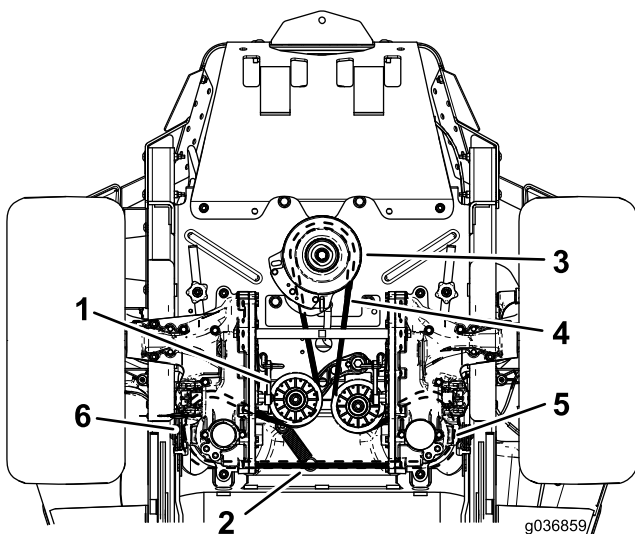

Figure 67

- | | |
|----------------------|--------------------------------|
| 1. Idler pulley | 4. Pump-drive belt |
| 2. Idler-spring post | 5. Right hydraulic-pump pulley |
| 3. Engine pulley | 6. Left hydraulic-pump pulley |

9. Install the clutch stop (Figure 66).
10. Install the mower belt; refer to [Belt Maintenance](#) (page 47).

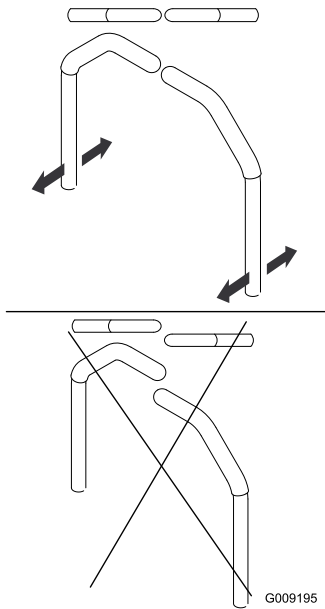

Figure 69

G009195

g009195

3. If the ends of the levers hit against each other, refer to [Adjusting the Motion-Control Linkage \(page 50\)](#).

Adjusting the Motion-Control Linkage

Located on either side of the machine, below the seat are the pump control linkages. Rotating the end nut with a 1/2 inch deep socket wrench allows fine tuning adjustments so that the machine does not move in neutral. Any adjustments should be made for neutral positioning only.

⚠ WARNING

Engine must be running and drive wheels must be turning so adjustments can be performed. Contact with moving parts or hot surfaces may cause personal injury.

Keep fingers, hands, and clothing clear of rotating components and hot surfaces.

1. Prior to starting the engine, push the deck lift pedal and remove the height of cut pin. Lower deck to the ground.
2. Raise the rear of the machine up and support it with jack stands (or equivalent support) just high enough to allow the drive wheels to turn freely.
3. Remove the electrical connection from the seat safety switch, located under the bottom cushion of the seat.

Note: The switch is a part of the seat assembly.

4. **Temporarily** install a jumper wire across the terminals in the connector of the main harness.

5. Start the engine. Run the engine at full throttle and release the parking brake.

Note: Ensure that the parking brake is engaged and that the motion-control levers are out to start the engine. You do not have to be in the seat.
6. Run the machine at least 5 minutes with the drive levers in the full forward speed to bring hydraulic fluid up to operating temperature.

Note: The motion-control lever must be in neutral while making any necessary adjustments.
7. Bring the motion-control levers into the NEUTRAL position.
8. Check and ensure that the control-plate tabs touch the return-to-neutral plates on the hydraulic units.
9. Adjust the pump-control-rod lengths by turning the nut in the appropriate direction until the wheels slightly creep in reverse (see [Figure 70](#)).
10. Move the motion-control levers to the REVERSE position and while applying slight pressure to the lever, allow the reverse indicator springs to bring the levers back to neutral.

Note: The wheels must stop turning or slightly creep in reverse.

Note: You may need to remove the motion-control cover to gain access.

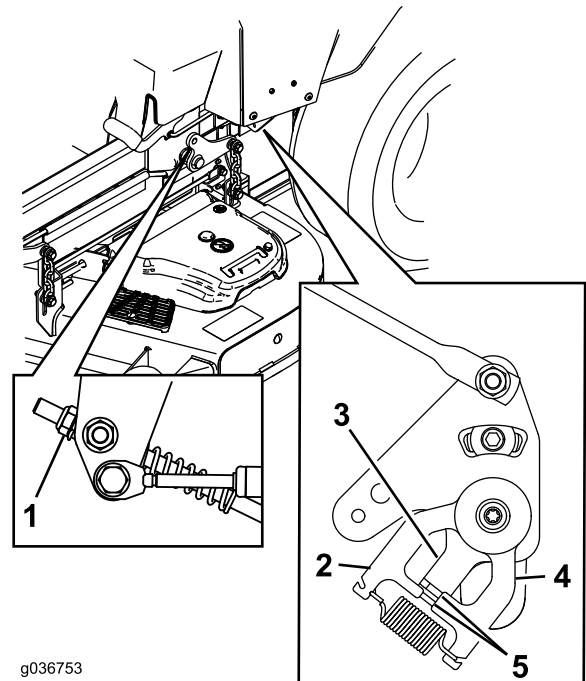

g036753

g036753

Figure 70

- | | |
|---------------------|--|
| 1. Nut | 4. Return-to-neutral plate |
| 2. Stationary plate | 5. Tabs touching return to neutral plate |
| 3. Control plate | |

11. Shut off the machine.
12. Remove the jumper wire from the wire harness and plug the connector into the seat switch.
13. Remove the jack stands.
14. Raise the mower deck and install the height of cut pin.
15. Check and ensure that the machine does not creep in neutral with the park brake disengaged.

Hydraulic System Maintenance

Hydraulic System Safety

- Ensure that all hydraulic-fluid hoses and lines are in good condition and all hydraulic connections and fittings are tight before applying pressure to the hydraulic system.
- Keep your body and hands away from pinhole leaks or nozzles that eject high-pressure hydraulic fluid.
- Use cardboard or paper to find hydraulic leaks.
- Safely relieve all pressure in the hydraulic system before performing any work on the hydraulic system.
- Seek immediate medical attention if fluid is injected into skin. Injected fluid must be surgically removed within a few hours by a doctor.

Servicing the Hydraulic System

Hydraulic Fluid Type: Toro® HYPR-OIL™ 500 hydraulic fluid (preferred) or Mobil 1 15W-50 oil.

Important: Use the fluid specified. Other fluids could cause system damage.

Hydraulic System Capacity (with filters removed): 4.45 L (150 oz)

Checking the Hydraulic Fluid Level

Service Interval: Before each use or daily

1. Allow the hydraulic fluid to cool down. Check the oil level when the oil is cold.
2. Check expansion reservoir and if necessary add Toro® HYPR-OIL™ 500 hydraulic fluid to the FULL COLD line.

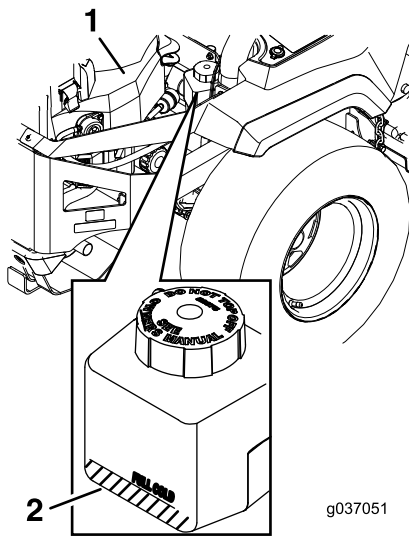

Figure 71

1. Engine

2. Expansion tank

Changing the Hydraulic-System Filters and Fluid

Service Interval: After the first 75 hours—Change the hydraulic-system filters and fluid.

Every 500 hours—After the initial change—change the hydraulic-system filters and fluid when using Toro® HYPR-OIL™ 500 oil (change it more often under severe conditions).

Every 250 hours—After the initial change—change the hydraulic-system filters and fluid when using Mobil 1 15W50 fluid (change it more often under severe conditions).

Change the filters and oil at the same time. **Do not** use the oil again. Purge any air in the system after you install the new filters and add oil. Refer to [Bleeding the Hydraulic System \(page 54\)](#).

Repeat the bleeding process until the oil remains at the FULL COLD line in the reservoir after purging. **Failure to properly perform this procedure can result in irreparable damage to the transaxle drive system.**

Removing Hydraulic-System Filters

1. Shut off the engine, wait for all moving parts to stop, allow the engine to cool, remove the key, and engage the parking brake.
2. Locate the filter and guards on each transaxle-drive system ([Figure 72](#)).
3. Remove the 3 screws securing the filter guard and guard ([Figure 72](#)).

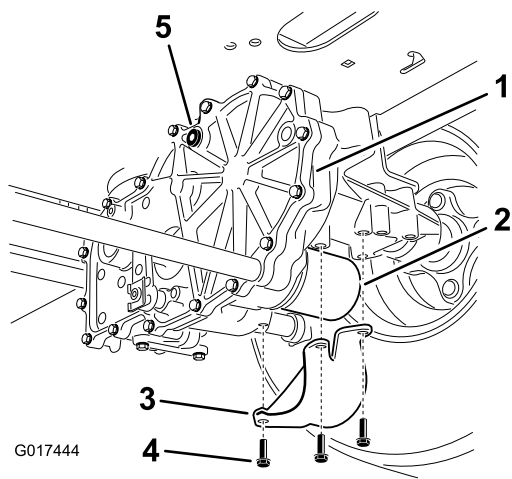

Figure 72
Right side shown

- | | |
|--------------------|--------------|
| 1. Transaxle drive | 4. Screws |
| 2. Oil filter | 5. Vent plug |
| 3. Filter guard | |

-
4. Carefully clean the area around the filters.

Important: Do not allow dirt to enter the hydraulic system, or contamination may occur.

5. Place a drain pan below the filter to catch the oil that drains when the filter and vent plug are removed.
6. Locate and remove the vent plug on each transmission
7. Unscrew the filter to remove it, and allow the oil to drain from the drive system.
8. Repeat this procedure for both filters.

Installing the Hydraulic-System Filters

1. Apply a thin coat of oil on the surface of the rubber seal of each filter.
2. Turn the filter clockwise until the rubber seal contacts the filter adapter, then tighten the filter an additional 3/4 to 1 full turn.
3. Repeat for the opposite filter.
4. Install the filter guards over each filter that you previously removed.
5. Use the 3 screws to secure the filter guards.
6. Verify that the vent plugs are removed before adding the oil.
7. Slowly pour the specified oil through the expansion reservoir until oil comes out of 1 of the vent-plug holes.
8. Install the vent plug.
9. Torque the plug to 20 N·m (15 ft-lb).
10. Continue to add oil through the expansion reservoir until oil comes out of the remaining vent-plug hole on the second transmission.
11. Install the opposite vent plug.
12. Torque the plug to 20 N·m (15 ft-lb).
13. Continue to add oil through the expansion reservoir until it reaches the FULL COLD line on the expansion reservoir.
14. Proceed to [Bleeding the Hydraulic System \(page 54\)](#).

Important: Failure to perform the *Bleeding the Hydraulic System* procedure after changing hydraulic filters and oil can result in irreparable damage to the transaxle drive system.

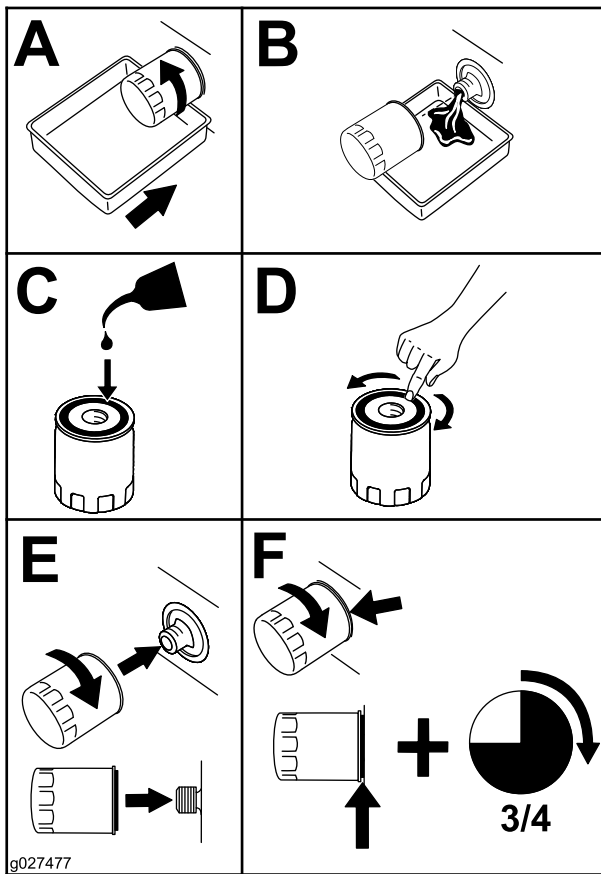

Figure 73

Bleeding the Hydraulic System

1. Raise the rear of machine and support it with jack stands (or equivalent support) just high enough to allow the drive wheels to turn freely.

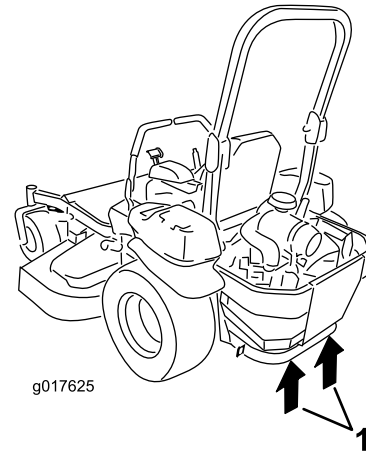

Figure 74

1. Jacking points
-
2. Start the engine, move the throttle control ahead to the 1/2 throttle position, and disengage the parking brake.
 - A. Move the bypass levers into the pushing the machine position. With the bypass valves open and the engine running, slowly move the motion-control levers in both forward and reverse 5 or 6 times.
 - B. Move the bypass levers into the operating the machine position.
 - C. With the bypass valve closed and the engine running, slowly move the control lever in both forward and reverse directions 5 to 6 times.
 - D. Shut off the engine and check the oil level in the expansion reservoir. Add the specified oil until it reaches the FULL COLD line on the expansion reservoir.
 3. Repeat step 2 until all the air is completely purged from the system.

Note: When the transaxle operates at normal noise levels, moves smoothly forward, and reverses at normal speeds, it is purged.

4. Check the oil level in the expansion reservoir a final time. Add the specified oil as until it reaches the FULL COLD line on the expansion reservoir.

Mower Deck Maintenance

Leveling the Mower Deck

Adjusting the Side-to-Side Leveling and the Blade Slope

1. Position the mower on a flat surface.
2. Disengage the blade-control switch (PTO), move the motion-control levers to the NEUTRAL-LOCK position, and engage the parking brake.
3. Shut off the engine, remove the key, and wait for all moving parts to stop before leaving the operating position.
4. Check the tire pressure in the drive tires. Refer to [Checking the Tire Pressure \(page 45\)](#).
5. Position the mower deck in the transport-lock position.
6. Carefully rotate the blades from side to side.
7. Measure between the blade tip and the flat surface ([Figure 75](#)). If both measurements are not within 5 mm (3/16 inch), adjust the leveling; continue with this procedure.

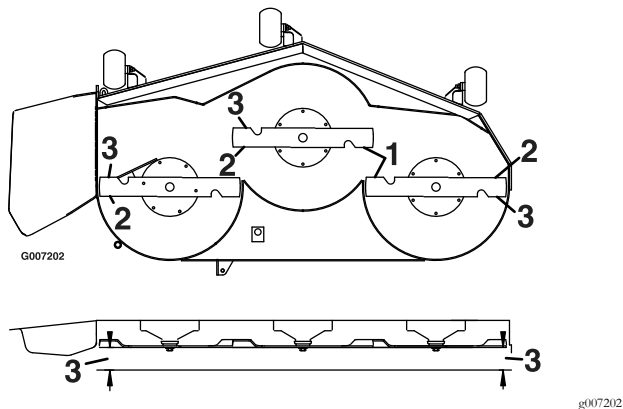

Figure 75

1. Blades side to side
2. Blade tip
3. Measure from the tip of the blade to the flat surface here.

8. Check the front-to-rear blade level ([Figure 76](#)). Ensure the front blade tip is lower than the rear blade tip as shown in the block height and rake table. If adjustment is needed, continue with this procedure.

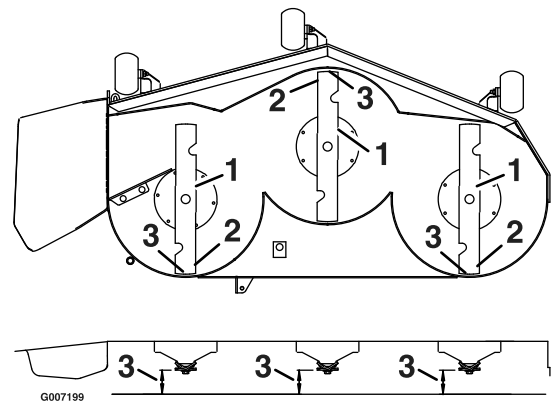

Figure 76

1. Blades front to rear
2. Blade tip
3. Measure from the tip of the blade to the flat surface here.

9. Set the anti-scalp rollers to top holes or remove them completely for this adjustment.
10. Place 2 blocks (see Block Height and Rake Table) under the rear edge of the cutting deck skirt; 1 on each side of the cutting deck ([Figure 77](#)).
11. Set the height-of-cut lever to the 3 inch (76 mm) position.
12. Place 2 blocks under each side of the front edge of the deck, but not under the anti-scalp roller brackets or welds.

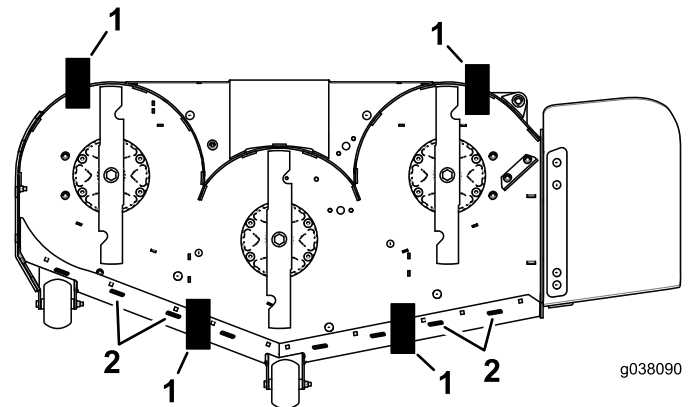

Figure 77
Bottom view

1. Block—7.3 cm (2.87 inches)
2. Welds

Block Height and Rake Table

Deck Size	Front Block Height	Rake
All mower decks	7.3 cm (2.87 inches)	4.8–6.4 mm (3/16–1/4 inch)

13. Carefully rotate the blades side to side ([Figure 75](#)).

14. Loosen the locknuts (Figure 78) on all 4 corners and ensure that the mower deck is sitting securely on all 4 blocks.
15. Remove any slack from the deck hangers and make sure the deck-lift foot lever is pushed back against the stop.
16. Tighten the 4 locknuts.

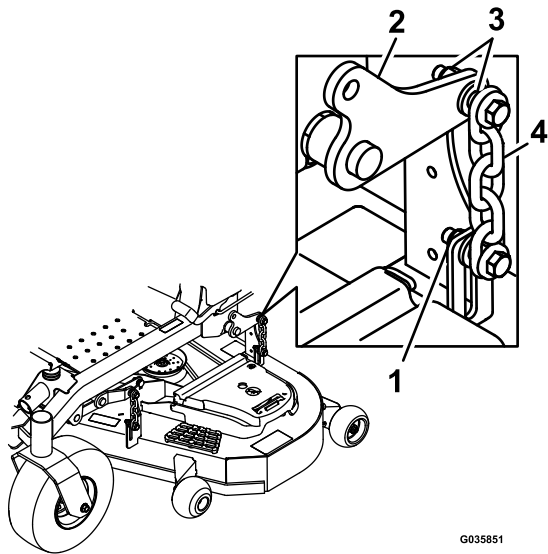

Figure 78

- | | |
|------------------|----------------|
| 1. Locknuts | 3. Deck hanger |
| 2. Deck lift arm | 4. Chain |

17. Ensure that the blocks fit snugly under the deck skirt and that all attachment bolts are tight
18. Continue leveling the deck by checking the front-to-rear blade slope.
19. Check the blades for levelness and repeat deck leveling procedure if necessary.

Servicing the Cutting Blades

To ensure a superior quality of cut, keep the blades sharp. For convenient sharpening and replacement, you may want to keep extra blades on hand.

Blade Safety

A worn or damaged blade can break, and a piece of the blade could be thrown toward you or bystanders, resulting in serious personal injury or death. Trying to repair a damaged blade may result in discontinued safety certification of the product.

- Inspect the blades periodically for wear or damage.
- Use care when checking the blades. Wrap the blades or wear gloves, and use caution when servicing the blades. Only replace or sharpen the blades; never straighten or weld them.
- On multi-bladed machines, take care as rotating 1 blade can cause other blades to rotate.

Before Inspecting or Servicing the Blades

1. Park the machine on a level surface, disengage the blade-control switch (PTO), and engage the parking brake.
2. Shut off the engine, remove the key, and disconnect the spark-plug wires from the spark plugs.

Inspecting the Blades

Service Interval: Before each use or daily

1. Inspect the cutting edges (Figure 79).
2. If the edges are not sharp or have nicks, remove and sharpen the blade; refer to (page).
3. Inspect the blades, especially in the curved area.
4. If you notice any cracks, wear, or a slot forming in this area, immediately install a new blade (Figure 79).

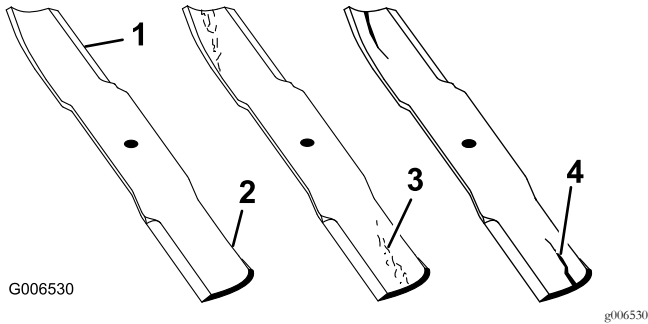

Figure 79

- | | |
|-----------------|----------------------|
| 1. Cutting edge | 3. Wear/slot forming |
| 2. Curved area | 4. Crack |

Checking for Bent Blades

1. Disengage the blade-control switch (PTO), move the motion-control levers to the NEUTRAL-LOCK position, and engage the parking brake.
2. Shut off the engine, remove the key, and wait for all moving parts to stop before leaving the operating position.
3. Rotate the blades until the ends face forward and backward.
4. Measure from a level surface to the cutting edge, position A, of the blades (Figure 80).

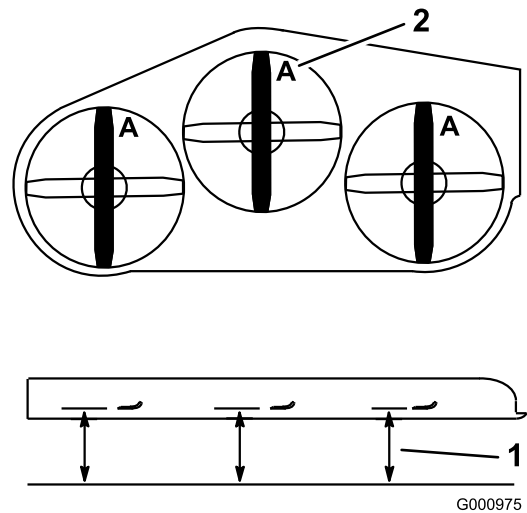

Figure 80

1. Measure here from blade
2. Position A to hard surface

5. Rotate the opposite ends of the blades forward.
6. Measure from a level surface to the cutting edge of the blades at the same position as in step 4 above.

Note: The difference between the dimensions obtained in steps 4 and 6 must not exceed 3 mm (1/8 inch).

Note: If this dimension exceeds 3 mm (1/8 inch), the blade is bent and must be replaced.

⚠ WARNING

A blade that is bent or damaged could break apart and could seriously injure or kill you or bystanders.

- Always replace a bent or damaged blade with a new blade.
- Do not file or create sharp notches in the edges or surfaces of the blade.

Removing the Blades

Blades must be replaced if a solid object is hit, if the blade is out of balance, or if the blade is bent. To ensure optimum performance and continued safety conformance of the machine, use genuine Toro replacement blades. Replacement blades made by other manufacturers may result in nonconformance with safety standards.

1. Hold the spindle shaft with a wrench.
2. Remove the blade bolt, the curved washer, and the blade from the spindle shaft (Figure 81).

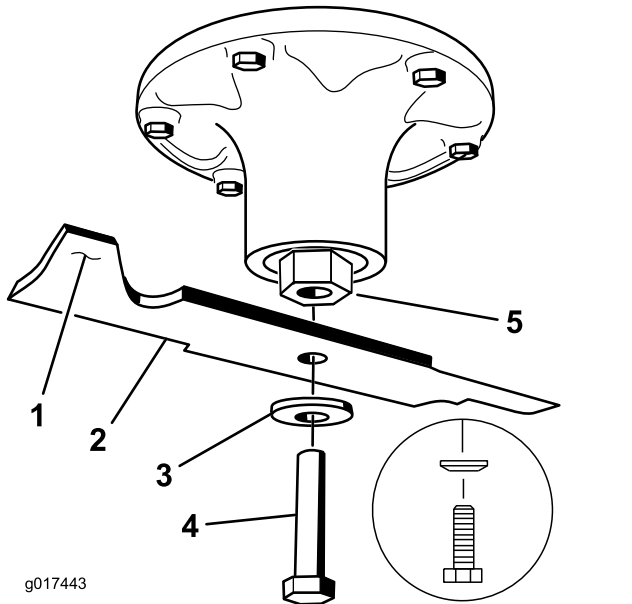

Figure 81

- | | |
|---------------------------|------------------|
| 1. Sail area of the blade | 4. Blade bolt |
| 2. Blade | 5. Spindle shaft |
| 3. Curved washer | |

Sharpening the Blades

1. Use a file to sharpen the cutting edge at both ends of the blade (Figure 82).

Note: Maintain the original angle.

Note: The blade retains its balance if the same amount of material is removed from both cutting edges.

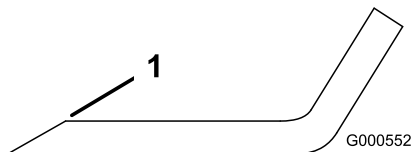

Figure 82

1. Sharpen at original angle.
2. Check the balance of the blade by putting it on a blade balancer (Figure 83).

Note: If the blade stays in a horizontal position, the blade is balanced and can be used.

Note: If the blade is not balanced, file some metal off the end of the sail area only (Figure 82).

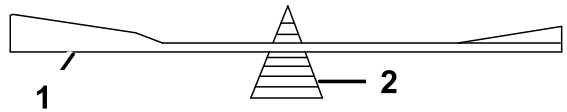

Figure 83

- | | |
|----------|-------------|
| 1. Blade | 2. Balancer |
|----------|-------------|

3. Repeat this procedure until the blade is balanced.

Installing the Blades

1. Install the blade onto the spindle shaft (Figure 84).

Important: The curved part of the blade must be pointing upward toward the inside of the mower to ensure proper cutting.

2. Install the spring disk and blade bolt (Figure 84).

Note: The spring-disk cone must be installed toward the bolt head (Figure 84).

3. Torque the blade bolt to 115 to 150 N·m (85 to 110 ft-lb).

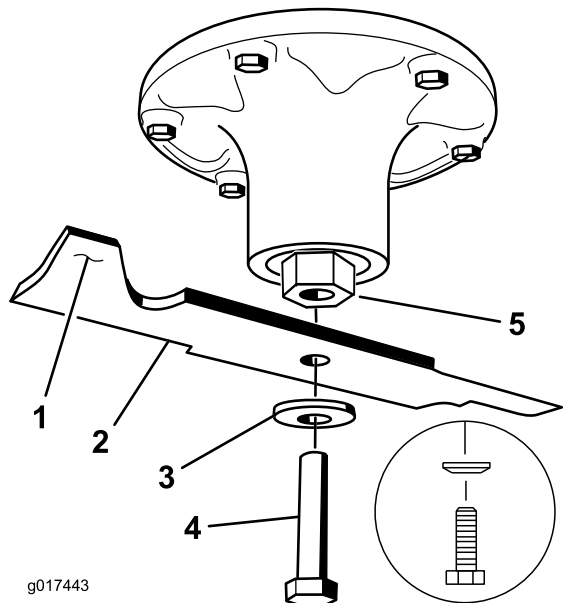

Figure 84

- | | |
|---------------------------|------------------|
| 1. Sail area of the blade | 4. Blade bolt |
| 2. Blade | 5. Spindle shaft |
| 3. Spring disk | |

Removing the Mower Deck

1. Shut off the engine, wait for all moving parts to stop, and remove the key. Engage the parking brake.
2. Remove the height adjustment pin and lower the deck to the ground.
3. Place the height-adjustment pin in the 7.6 cm (3 inch) cutting-height location.
4. Remove the belt covers.
5. Loosen the mower deck idler and remove the mower belt; refer to [Belt Maintenance](#) (page 47).
6. Remove the bolts and nuts from the front of the plate under the footrest.
7. Remove and retain the bolts and nuts on both sides of the machine ([Figure 85](#)).

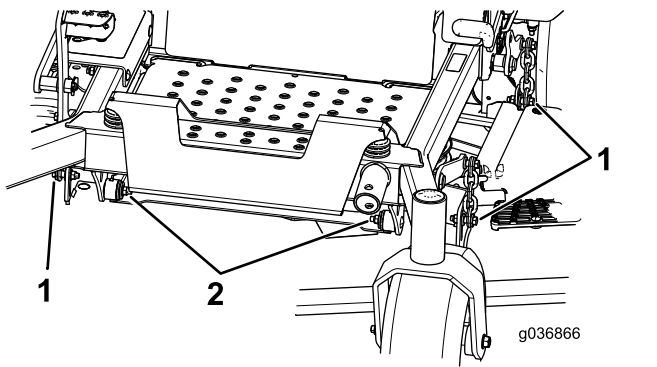

Figure 85

1. Remove the nuts and bolts here.
2. Remove the nuts and bolts here.

8. Slide the deck out to the right side of the machine.

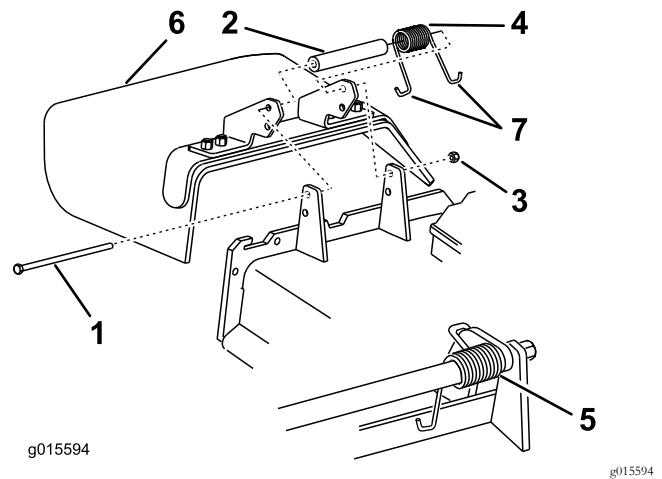

Figure 86

- | | |
|------------|-------------------------|
| 1. Bolt | 5. Spring installed |
| 2. Spacer | 6. Grass deflector |
| 3. Locknut | 7. J-hook end of spring |
| 4. Spring | |

3. Place the spacer and the spring onto grass deflector.
4. Place 1 J-hook end of the spring behind the deck edge.

Note: Make sure that 1 J-hook end of the spring is installed behind the deck edge before installing the bolt as shown in [Figure 86](#).

5. Install the bolt and the nut.
6. Place 1 J-hook end of the spring around the grass deflector ([Figure 86](#)).

Important: The grass deflector must be able to rotate. Lift the deflector up to the full open position and ensure that it rotates into the full down position.

Replacing the Grass Deflector

⚠ WARNING

An uncovered discharge opening could allow the lawn mower to throw objects at you or bystanders, resulting in serious injury. Also, contact with the blade could occur.

Do not operate the lawn mower unless you install a cover plate, mulch plate, grass deflector, or bagger.

1. Remove the locknut, bolt, spring, and spacer holding the deflector to the pivot brackets ([Figure 86](#)).
2. Remove the damaged or worn grass deflector ([Figure 86](#)).

Cleaning

Cleaning under the Mower

Service Interval: Before each use or daily

1. Disengage the blade-control switch (PTO), move the motion-control levers to the NEUTRAL-LOCK position, and engage the parking brake.
2. Shut off the engine, remove the key, and wait for all moving parts to stop before leaving the operating position.
3. Raise the mower to the transport position.

Disposing of Waste

Engine oil, batteries, hydraulic oil, and engine coolant are pollutants to the environment. Dispose of these according to your state and local regulations.

Storage

Cleaning and Storing the Machine

1. Disengage the blade-control switch (PTO), engage the parking brake, turn the ignition key to the OFF position, and remove the key.
2. Remove grass clippings, dirt, and grime from the external parts of the entire machine (especially the engine and hydraulic system). Clean dirt and chaff from the outside of the engine-cylinder-head fins and the blower housing.

Important: You can wash the machine with mild detergent and water. Do not pressure-wash the machine. Avoid excessive use of water, especially near the control panel, engine, hydraulic pumps, and motors.

3. Check the brake; refer to [Adjusting the Parking Brake \(page 46\)](#).
4. Service the air cleaner; refer to [Servicing the Air Cleaner \(page 35\)](#).
5. Grease the machine; refer to [Greasing the Machine \(page 34\)](#).
6. Change the crankcase oil; refer to [Changing the Engine Oil and Oil Filter \(page 36\)](#).
7. Check the tire pressure; refer to [Checking the Tire Pressure \(page 45\)](#).
8. Change the hydraulic filters; refer to [Changing the Hydraulic-System Filters and Fluid \(page 52\)](#).
9. Charge the battery; refer to [Charging the Battery \(page 42\)](#).
10. Scrape any heavy buildup of grass and dirt from the underside of the mower, then wash the mower with a garden hose.

Note: Run the machine with the blade-control switch (PTO) engaged and the engine at high idle for 2 to 5 minutes after washing.

11. Check the condition of the blades; refer to [Inspecting the Blades \(page 58\)](#).
12. Prepare the machine for storage when non-use occurs over 30 days. Prepare the machine for storage as follows:
 - A. Add a petroleum based stabilizer/conditioner to fuel in the tank. Follow mixing instructions from the stabilizer manufacturer. Do not use an alcohol based stabilizer (ethanol or methanol).

Note: A fuel stabilizer/conditioner is most effective when mixed with fresh fuel and used at all times.

- B. Run the engine to distribute conditioned fuel through the fuel system (5 minutes).
- C. Shut off the engine, allow it to cool, and drain the fuel tank; contact an Authorized Toro Dealer.
- D. Start the engine and run it until it stops.
- E. Dispose of fuel properly. Recycle as per local codes.

Important: Do not store stabilizer/conditioned fuel over 90 days.

- 13. Check and tighten all bolts, nuts, and screws. Repair or replace any part that is damaged.
- 14. Paint all scratched or bare metal surfaces. Paint is available from your Authorized Service Dealer.
- 15. Store the machine in a clean, dry garage or storage area.
- 16. Remove the key from the ignition switch and keep it out of reach of children or other unauthorized users.
- 17. Cover the machine to protect it and keep it clean.

Troubleshooting

Problem	Possible Cause	Corrective Action
The starter does not crank.	<ol style="list-style-type: none"> 1. The blade-control switch (PTO) is engaged. 2. The parking brake is not on. 3. The motion-control levers are not in the neutral-lock position. 4. The operator is not seated. 5. The battery is dead. 6. The electrical connections are corroded or loose. 7. The fuse is blown. 8. The relay or switch is worn or damaged. 	<ol style="list-style-type: none"> 1. Move the blade-control switch (PTO) to the disengaged position. 2. Engage the parking brake. 3. Ensure that the motion-control levers are in the neutral-lock position. 4. Sit on the seat. 5. Charge the battery. 6. Check the electrical connections for good contact. 7. Replace the fuse. 8. Contact an Authorized Service Dealer.
The engine does not start, starts hard, or fails to keep running.	<ol style="list-style-type: none"> 1. The fuel tank is empty. 2. The fuel-shutoff valve is closed. 3. The oil level in the crankcase is low. 4. The throttle is not in the correct position. 5. There is dirt in the fuel filter. 6. There is dirt, water, or stale fuel in the fuel system. 7. The air cleaner is dirty. 8. The seat switch is not functioning properly. 9. The electrical connections are corroded, loose, or damaged. 10. The relay or switch is worn or damaged. 11. The spark plug is fouled or improperly gapped. 12. The spark-plug wire is not connected. 	<ol style="list-style-type: none"> 1. Fill the fuel tank. 2. Open the fuel-shutoff valve. 3. Add oil to the crankcase. 4. Be sure that the throttle control is midway between the slow and fast positions. 5. Replace the fuel filter. 6. Contact an Authorized Service Dealer. 7. Clean or replace the air-cleaner element. 8. Check the seat-switch indicator. Replace the seat if necessary. 9. Check the electrical connections for good contact. Clean the connector terminals thoroughly with electrical-contact cleaner, apply dielectric grease, and make the appropriate connections. 10. Contact an Authorized Service Dealer. 11. Adjust or replace the spark plug. 12. Check the spark-plug wire connection.
The engine loses power.	<ol style="list-style-type: none"> 1. The engine load is excessive. 2. The air cleaner is dirty. 3. The oil level in the crankcase is low. 4. The cooling fins and the air passages above the engine are plugged. 5. The vent hole in the fuel cap is plugged. 6. There is dirt in the fuel filter. 7. There is dirt, water, or stale fuel in the fuel system. 	<ol style="list-style-type: none"> 1. Reduce the ground speed. 2. Clean the air-cleaner element. 3. Add oil to the crankcase. 4. Remove the obstruction from the cooling fins and the air passages. 5. Clean or replace the fuel cap. 6. Replace the fuel filter. 7. Contact an Authorized Service Dealer.
The engine overheats.	<ol style="list-style-type: none"> 1. The engine load is excessive. 2. The oil level in the crankcase is low. 3. The cooling fins and the air passages above the engine are plugged. 	<ol style="list-style-type: none"> 1. Reduce the ground speed. 2. Add oil to the crankcase. 3. Remove the obstruction from the cooling fins and the air passages.
The mower pulls to the left or right (with levers fully forward).	<ol style="list-style-type: none"> 1. The tracking needs adjustment 2. The tire pressure in the drive tires is not correct. 	<ol style="list-style-type: none"> 1. Adjust the tracking. 2. Adjust the tire pressure in the drive tires.

Problem	Possible Cause	Corrective Action
The machine does not drive.	<ol style="list-style-type: none"> 1. The bypass valves are not closed tight. 2. The pump belt is worn, loose, or broken. 3. The pump belt is off a pulley. 4. The idler spring is broken or missing. 5. The hydraulic oil level is low or too hot. 	<ol style="list-style-type: none"> 1. Tighten the bypass valves. 2. Change the belt. 3. Change the belt. 4. Replace the spring. 5. Add hydraulic oil to the reservoirs or let it cool down.
The machine vibrates abnormally.	<ol style="list-style-type: none"> 1. The cutting blade(s) is/are bent or unbalanced. 2. The blade mounting bolt is loose. 3. The engine mounting bolts are loose. 4. The engine pulley, idler pulley, or blade pulley is loose. 5. The engine pulley is damaged. 6. The blade spindle is bent. 7. The motor mount is loose or worn. 	<ol style="list-style-type: none"> 1. Install new cutting blade(s). 2. Tighten the blade mounting bolt. 3. Tighten the engine mounting bolts. 4. Tighten the appropriate pulley. 5. Contact an Authorized Service Dealer. 6. Contact an Authorized Service Dealer. 7. Contact an Authorized Service Dealer.
The machine produces an uneven cutting height.	<ol style="list-style-type: none"> 1. The blade(s) is/are not sharp. 2. The cutting blade(s) is/are bent. 3. The mower deck is not level. 4. The underside of mower is dirty. 5. The tire pressure is not correct. 6. The blade spindle is bent. 	<ol style="list-style-type: none"> 1. Sharpen the blade(s). 2. Install new cutting blade(s). 3. Level the mower deck from side-to-side and front-to-rear. 4. Clean the underside of the mower. 5. Adjust the tire pressure. 6. Contact an Authorized Service Dealer.
The blades do not rotate.	<ol style="list-style-type: none"> 1. The mower deck belt is worn, loose, or broken. 2. The mower deck belt is off pulley. 3. The pump drive belt is worn, loose, or broken. 4. The idler spring is broken or missing. 	<ol style="list-style-type: none"> 1. Install a new deck belt. 2. Install the mower deck pulley and check the idler pulley, idler arm, and spring for correct position and function. 3. Check the belt tension or install a new belt. 4. Replace the spring.
The clutch does not engage.	<ol style="list-style-type: none"> 1. The fuse is blown. 2. There is low voltage supply at the clutch. 3. The coil is damaged. 4. There is inadequate current supply. 5. The rotor/armature air gap is too large. 	<ol style="list-style-type: none"> 1. Replace the fuse. Check the coil resistance, battery charge, charging system, and wiring connections, and replace components if necessary. 2. Check the coil resistance, battery charge, charging system, and wiring connections and replace parts if necessary. 3. Replace the clutch. 4. Repair or replace the clutch lead wire or electrical system. Clean the connector contacts. 5. Remove the shim or replace the clutch.

Schematics

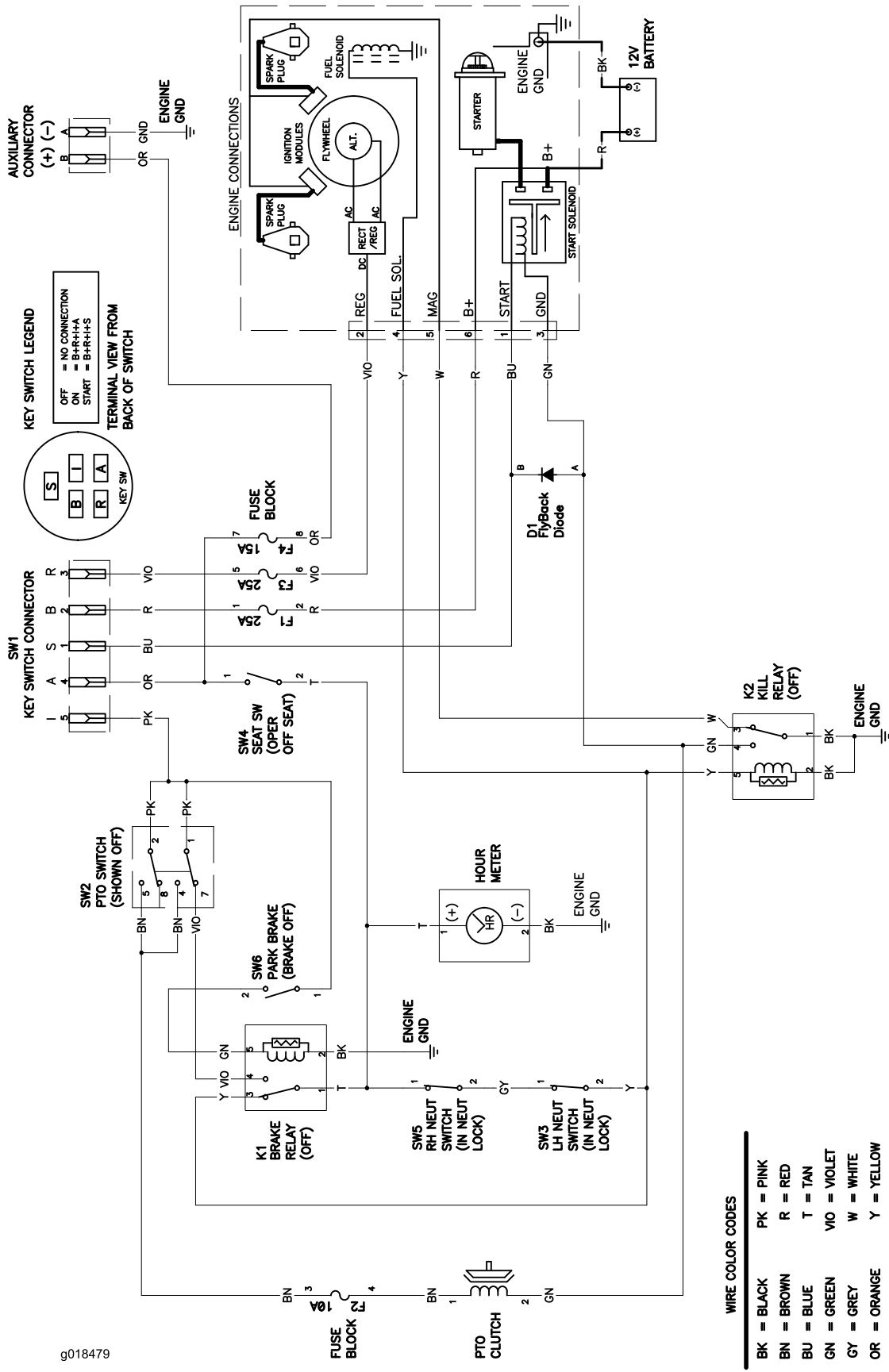

g018479

Wire Diagram—Toro Engines (Rev. A)

g018479

Notes:

European Privacy Notice

The Information Toro Collects

Toro Warranty Company (Toro) respects your privacy. In order to process your warranty claim and contact you in the event of a product recall, we ask you to share certain personal information with us, either directly or through your local Toro company or dealer.

The Toro warranty system is hosted on servers located within the United States where privacy law may not provide the same protection as applies in your country.

BY SHARING YOUR PERSONAL INFORMATION WITH US, YOU ARE CONSENTING TO THE PROCESSING OF YOUR PERSONAL INFORMATION AS DESCRIBED IN THIS PRIVACY NOTICE.

The Way Toro Uses Information

Toro may use your personal information to process warranty claims, to contact you in the event of a product recall and for any other purpose which we tell you about. Toro may share your information with Toro's affiliates, dealers or other business partners in connection with any of these activities. We will not sell your personal information to any other company. We reserve the right to disclose personal information in order to comply with applicable laws and with requests by the appropriate authorities, to operate our systems properly or for our own protection or that of other users.

Retention of your Personal Information

We will keep your personal information as long as we need it for the purposes for which it was originally collected or for other legitimate purposes (such as regulatory compliance), or as required by applicable law.

Toro's Commitment to Security of Your Personal Information

We take reasonable precautions in order to protect the security of your personal information. We also take steps to maintain the accuracy and current status of personal information.

Access and Correction of your Personal Information

If you would like to review or correct your personal information, please contact us by email at legal@toro.com.

Australian Consumer Law

Australian customers will find details relating to the Australian Consumer Law either inside the box or at your local Toro Dealer.



The Toro Warranty

Landscape
Contractor
Equipment (LCE)

Conditions and Products Covered

The Toro Company and its affiliate, Toro Warranty Company, pursuant to an agreement between them, jointly promise to repair the Toro Products listed below if defective in materials or workmanship.

The following time periods apply from the original date of purchase:

Products	Warranty Period
Walk Behind Mowers	
53 cm & 76 cm Mowers – Residential use ¹	2 years
53 cm & 76 cm Mowers – Commercial use	1 year
• Engine	2 years ²
Mid-Size Walk-Behind Mowers	2 years
• Engine	2 years ²
Grand Stand® Mowers	5 years or 1,200 hours ³
• Engine	3 years
Z Master® 6000 Series Mowers	5 years or 1,200 hours ³
• Engine	3 years ²
Z Master® 7000 Series Mowers	5 years or 1,200 hours ³
• Engine	2 years ²
Z Master® 8000 Series Mowers	2 years
• Engine	3 years ²
Titan HD Mower and Engine	4 years or 500 hours ³
All Mowers	
• Battery	2 years
• Attachments	2 years

¹Residential use means use of the product on the same lot as your home. Use at more than one location is considered commercial use and the commercial warranty would apply.

²Some engines used on Toro LCE Products are warranted by the engine manufacturer.

³Whichever occurs first.

This warranty includes the cost of parts and labor, but you must pay transportation costs.

Instructions for Obtaining Warranty Service

If you think that your Toro Product contains a defect in materials or workmanship, follow this procedure:

1. Contact your seller to arrange service of the product. If for any reason it is impossible for you to contact your seller, you may contact any Toro Authorized Distributor to arrange service. Visit <http://www.toro.com/> to locate a Toro distributor in your area.
2. Bring the product and your proof of purchase (sales receipt) to the Service Dealer.
3. If for any reason you are dissatisfied with the Service Dealer's analysis or with the assistance provided, contact us at:

Toro Warranty Company
8111 Lyndale Avenue South
Bloomington, MN 55420-1196
001-952-948-4707

Owner Responsibilities

You must maintain your Toro Product by following the maintenance procedures described in the *Operator's Manual*. Such routine maintenance, whether performed by a dealer or by you, is at your expense.

Items and Conditions Not Covered

There is no other express warranty except for special emission system coverage and engine warranty coverage on some products. This express warranty does not cover the following:

- Cost of regular maintenance service or parts, such as filters, fuel, lubricants, oil changes, spark plugs, air filters, blade sharpening or worn blades, cable/linkage adjustments, or brake and clutch adjustments
- Components failing due to normal wear
- Any product or part which has been altered or misused or neglected or requires replacement or repair due to accidents or lack of proper maintenance
- Pickup and delivery charges
- Repairs or attempted repairs by anyone other than an Authorized Toro Service Dealer
- Repairs necessary due to failure to follow recommended fuel procedure (consult the *Operator's Manual* for more details)
 - Removing contaminants from the fuel system is not covered
 - Use of old fuel (more than one month old) or fuel which contains more than 10% ethanol or more than 15% MTBE
 - Failure to drain the fuel system prior to any period of non-use over one month

General Conditions

The purchaser is covered by the national laws of each country. The rights to which the purchaser is entitled with the support of these laws are not restricted by this warranty.